

Pilot burner ZMI, ZMIC

Technical Information · GB
9 Edition 08.14l

- Pilot burner with forced air supply
- Safe flame control thanks to ionization electrode
- Reliable electrical ignition
- Space-saving slim design due to single-electrode operation
- Optimum positioning thanks to moveable mounting device
- Different lengths make it suitable for many installation situations
- Maintenance-friendly thanks to simple design
- Can be used in many applications
- Optional: ZMIC with ceramic tip

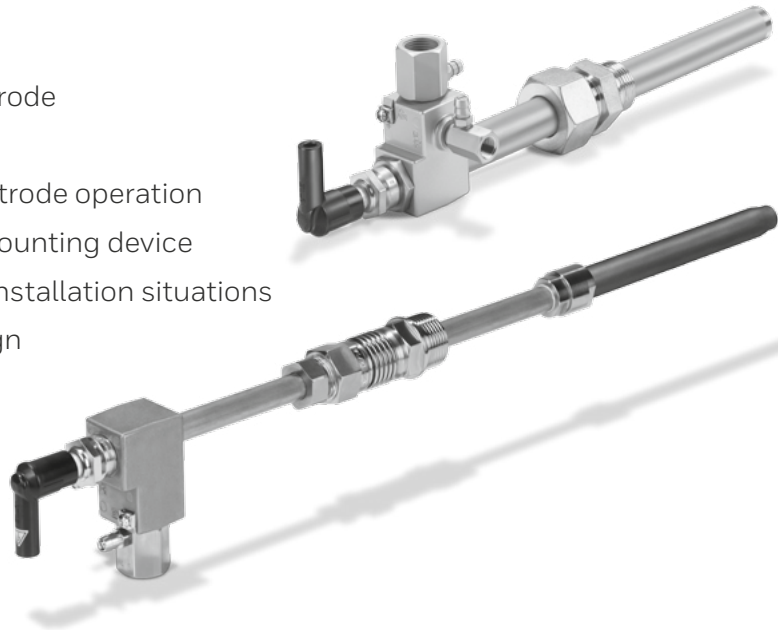

Contents

Pilot burner ZMI, ZMIC	1	7.1.4 ZMIC 28..K with bellows unit.....	17
Contents	2	7.2 Converting units.....	18
1 Application	3	8 Maintenance cycles	18
1.1 Examples of application	4	Feedback	19
1.1.1 Alternating pilot burner with modulating- controlled main burner.....	5	Contact	19
1.1.2 Igniting a flame curtain.....	5		
2 Certification	6		
2.1 Approval for Russia	6		
2.2 Declaration of Incorporation pursuant to the Machinery Directive	6		
3 Function	7		
4 Selection	8		
4.1 Pilot burner capacity.....	8		
4.2 Selection table.....	9		
4.3 Type code	9		
5 Project planning information	10		
5.1 Gas and air supply	10		
5.2 Installation.....	10		
5.2.1 ZMI in burner quarl.....	11		
5.2.2 ZMIC with bellows unit in burner quarl.....	11		
6 Accessories	12		
6.1 Gas nozzle	12		
6.2 High-voltage cable	12		
6.3 Ignition transformer	12		
6.4 Regulator 60DJZ.....	13		
6.5 Regulator J78R.....	13		
7 Technical data	14		
7.1 Dimensions.....	15		
7.1.1 ZMI 16 and ZMI 25.....	15		
7.1.2 ZMI 16T and ZMI 25T.....	15		
7.1.3 ZMIC 28 without bellows unit.....	16		

1 Application

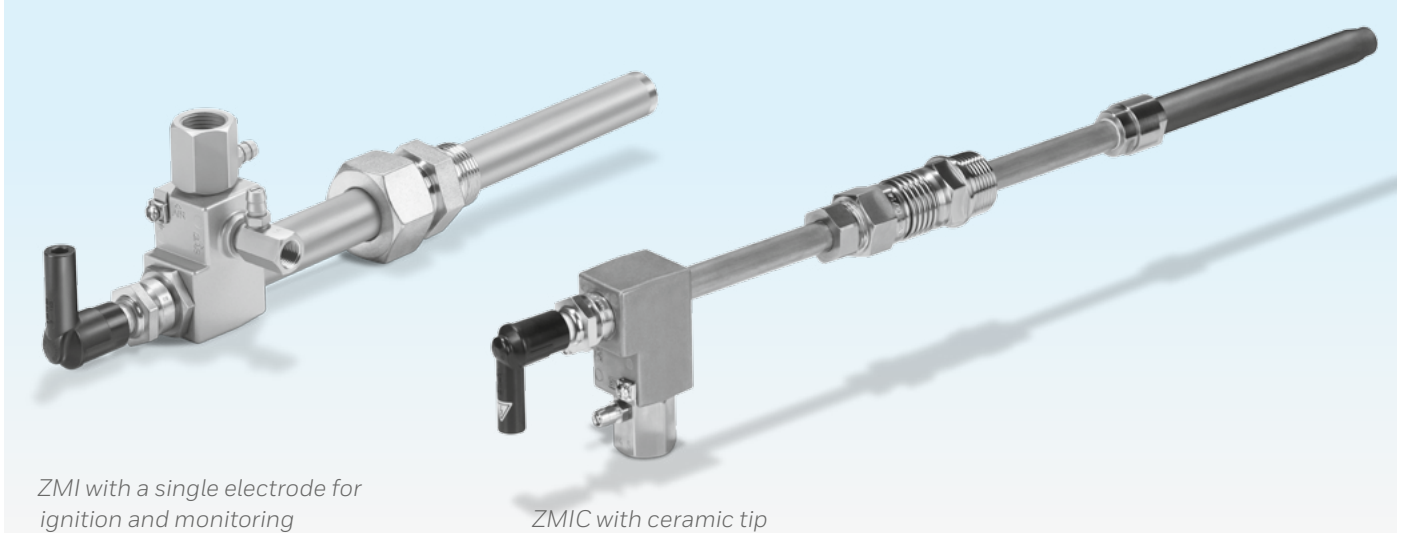

For safely igniting gas burners on furnaces in the metal, ceramics and non-ferrous metal industries and on heat treatment installations.

The ZMI can also be used as an independently operated burner.

Suitable for operation with natural gas, town gas/coke oven gas or LPG.

The pilot burner is ignited electronically and monitored by a single ignition and ionization electrode.

The ZMIC 28 with ceramic tip has a longer, sharper flame. The ceramic tube has a longer service life and is suitable for higher temperatures.

1.1 Examples of application

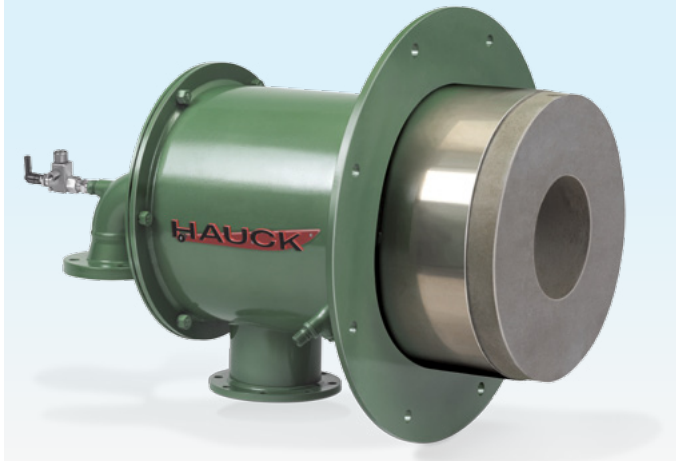

Main burner BBG with integrated pilot burner ZMI

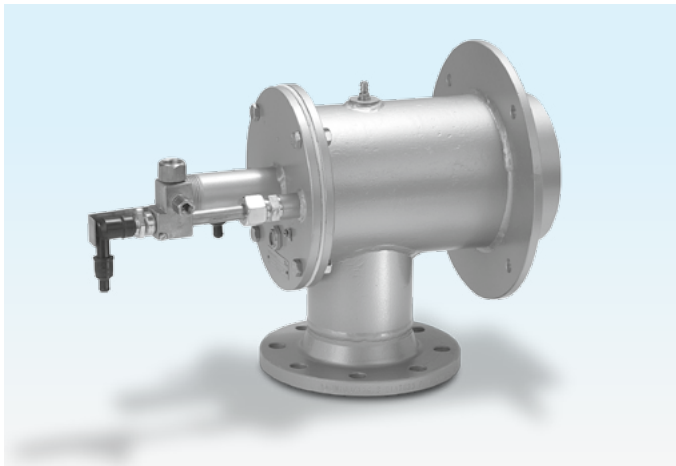

Main burner ZIO with integrated pilot burner ZMI

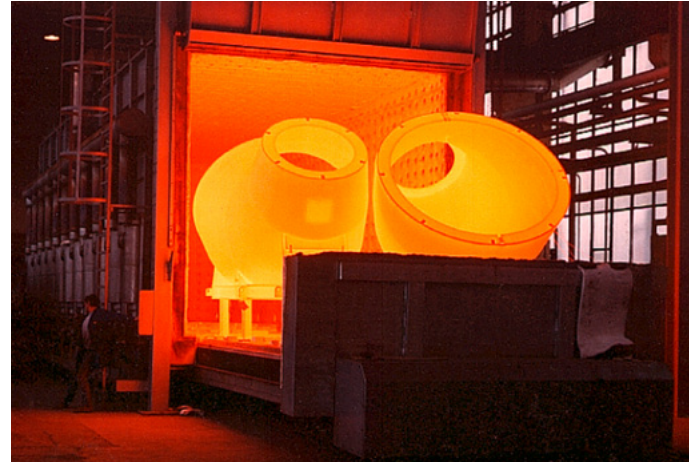

Industrial furnace for housings



Roller hearth kiln in the ceramics industry

Application

In the case of combined pilot and main burners, EN 746-2:2010 stipulates the monitoring of pilot and main burner via the automatic burner control unit. Exceptions are permitted provided that the safety of the installation is not impaired.

1.1.1 Alternating pilot burner with modulating-controlled main burner

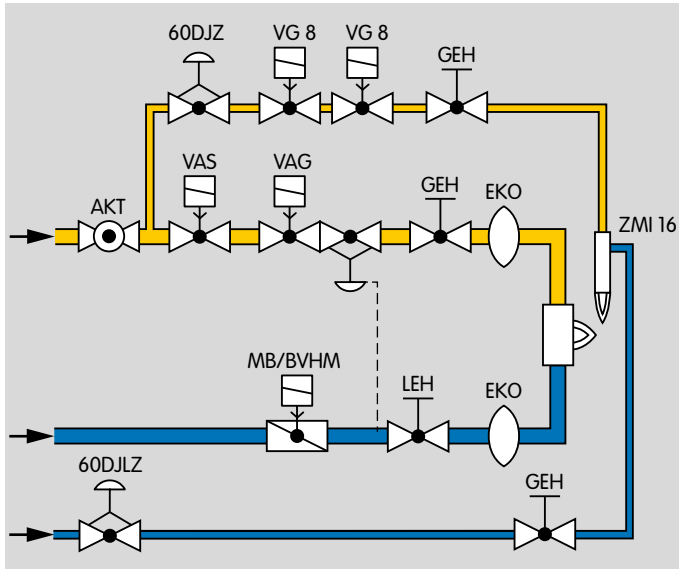

As soon as voltage is supplied to the ignition transformer, the pilot burner ZMI is ignited using an ignition spark. If the pilot burner detects a stable ionization signal, the enable signal for operation of the main burner is issued via the automatic burner control unit. The main burner

is ignited. If the main burner provides a stable flame signal, the pilot burner ZMI can be switched off.

1.1.2 Igniting a flame curtain

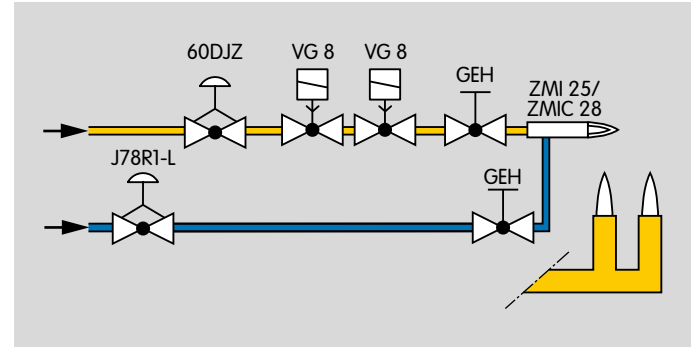

As soon as voltage is supplied to the ignition transformer, the pilot burner ZMI is ignited using an ignition spark. If the pilot burner provides a stable ionization signal, the enable signal for the flame curtain is then issued via the automatic burner control unit. The flame curtain is ignited.

2 Certification

2.1 Approval for Russia



Certified by Gosstandart under Technical Regulations.
Approved by Rostekhnadzor (RTN).

Scan of the approval for Russia (RUS) – see www.docuthek.com → Elster Kromschroder → Kromschroder, LBE → Products → 07 Pilot burners and burners → Ionization pilot burner ZMI → Kind of document: Certificate → ZMI B00050 (nationales Zertifikat Russland) (RUS)

2.2 Declaration of Incorporation pursuant to the Machinery Directive

The ZMI complies with the requirements of EN 746-2 and the Machinery Directive 2006/42/EC. This is confirmed by the manufacturer's Declaration of Incorporation.

3 Function

The pilot burners ZMI and ZMIC are equipped with a gas nozzle and an air nozzle for the respective gas type at the factory. Gas and air are supplied separately and mixed in the housing. The gas and air nozzles feature pressure test points.

The gas/air mixture is ignited using an ignition electrode at the burner head. The flame is produced downstream of the burner head. The electrode monitors it using ionization control (single-electrode operation).

ZMI

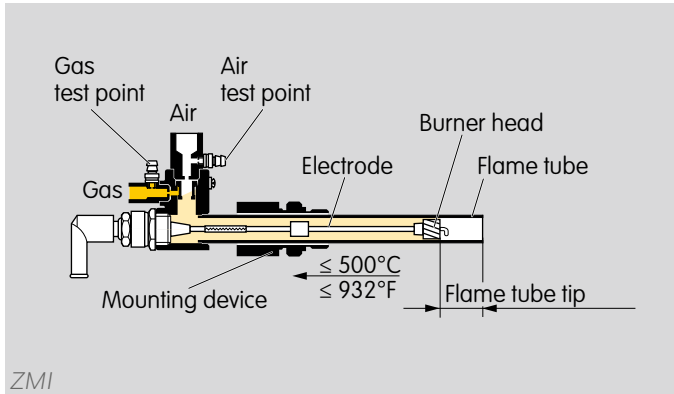

ZMIC

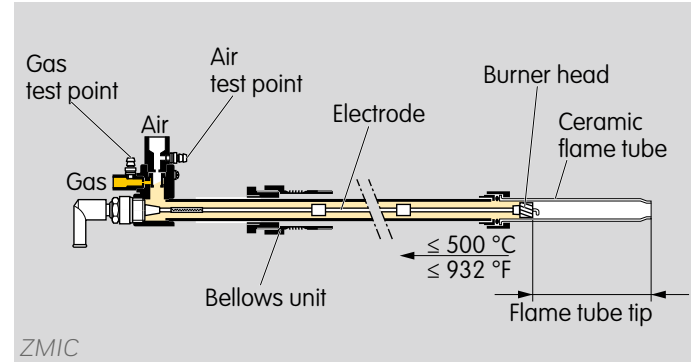

The ceramic flame tube of the ZMIC is made of SiC material (Si-1500) and has a considerably longer designed lifetime than the metallic variant ZMI when subject to high temperatures such as those experienced when installed in a burner quartl.

Due to the tapered combustion chamber, a longer, sharper flame is formed by the ZMIC. This is advantageous if the pilot burner flame can be deflected or cooled by the air flow from the main burner.

4 Selection

4.1 Pilot burner capacity

ZMI 16

Flame length approx. 4 cm (1.6 inches)

Gas type	Capacity [kW]	Gas pressure [mbar]	Air pressure [mbar]
Natural gas*	1 – 2	35 – 80	30 – 80
Propane	1.2 – 2	20 – 45	30 – 70
Town gas	1.3 – 2	30 – 70	30 – 80

Gas type	Capacity [10 ³ BTU/h]	Gas pressure [inch "WC]	Air pressure [inch WC]
Natural gas*	3.8 – 7.6	13.8 – 31.5	11.8 – 31.5
Propane	4.4 – 7.4	7.9 – 17.7	11.8 – 27.9
Town gas	5.0 – 7.8	11.8 – 27.9	11.8 – 31.5

* Measured using natural gas L

ZMI 25

Flame length approx. 6 cm (2.4 inches)

Gas type	Capacity [kW]	Gas pressure [mbar]	Air pressure [mbar]
Natural gas*	2.5 – 4.0	20 – 50	30 – 80
Propane	2.8 – 4.0	17 – 40	38 – 80
Town gas	1.5 – 3.3	20 – 70	20 – 80

Gas type	Capacity [10 ³ BTU/h]	Gas pressure [inch "WC]	Air pressure [inch "WC]
Natural gas*	9.5 – 15.1	7.9 – 19.7	11.8 – 31.5
Propane	10.4 – 14.8	6.7 – 15.7	15 – 31.5
Town gas	5.8 – 12.8	7.9 – 27.6	7.9 – 31.5

* Measured using natural gas L

ZMIC 28

Flame length approx. 10 cm (3.9 inches)

Gas type	Capacity [kW]	Gas pressure [mbar]	Air pressure [mbar]
Natural gas*	2.5 – 4.2	30 – 80	25 – 90
Propane	2 – 4.2	20 – 70	15 – 90
Town gas	2.5 – 4.2	40 – 100	30 – 110

Gas type	Capacity [10 ³ BTU/h]	Gas pressure [inch "WC]	Air pressure [inch "WC]
Natural gas*	9.5 – 15.9	11.8 – 31.5	9.8 – 35.4
Propane	7.4 – 15.6	7.9 – 27.6	5.9 – 35.4
Town gas	9.7 – 16.3	15.7 – 39.4	11.8 – 43.3

* Measured using natural gas L

Capacities in kW refer to the lower calorific value H_u and capacities in BTU/h refer to the upper calorific value H_o.

Flow rate curves for ZMI, ZMIC, see www.docuthek.com → Elster Kromschroder
Search term: ZMI, ZMIC

Kind of document: Flow rate curves

Registration required.

4.2 Selection table

	16	25	28	T	B	G	D	150	200	300...	R	N	K
ZMI	●	●		●	●	●	●	●	●	●	●	●	
ZMIC			●		●	●	●		●	●	●		○

● = standard, ○ = available

Order example

ZMI 16B200R

4.3 Type code

Code	Description
ZMI	Pilot burner
ZMIC	Pilot burner with ceramic flame tube
16	16 mm burner size
25	25 mm burner size
28	28 mm burner size
T	T-product
B	For natural gas
G	For LPG
D	For town gas/coke oven gas
150 200 300...	Flame tube length [mm]*
R	Rp internal thread
N	NPT internal thread
K	Bellows unit

* ZMI lengths as of 200 mm in 100 mm increments
 ZMIC lengths as of 300 mm in 100 mm increments
 ZMIC 28..K lengths as of 400 mm in 50 mm increments

5 Project planning information

5.1 Gas and air supply

Install pressure regulators and adjusting cocks in the air and gas supply lines upstream of the burner. Pressure regulator 60DJZ does not have zero shut-off. For this reason, the pressure regulator must be installed directly upstream of the gas solenoid valve to ensure that the gas volume between the pressure regulator and the gas solenoid valve is as low as possible.

Set pressure regulators for the gas and air supply pressures to the maximum admissible values, see page 13 (Regulator 60DJZ), whereby the gas and air supply pressures should be identical (approx. 80 mbar for igniting a main burner). Using the adjusting cocks, reduce the air and gas pressures to the required values for the pilot burner.

For maximum flame stability of the pilot burner, the gas and air pressures of the ZMI or the ZMIC must be higher than the connection pressure of the main burner.

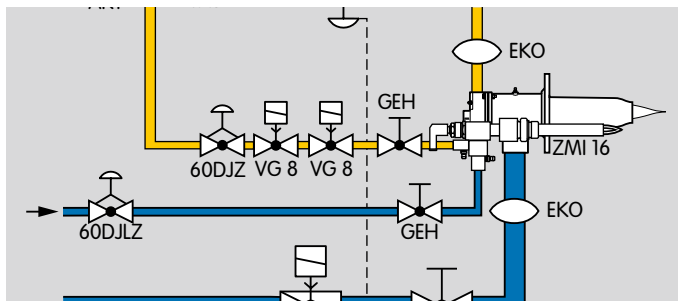

To protect the nozzles against soiling, we recommend installing filters in the gas and air circuits.

5.2 Installation

Install the pilot burner so that reliable ignition of the main burner is guaranteed.

The pilot burner tip can be positioned exactly using the moveable mounting device.

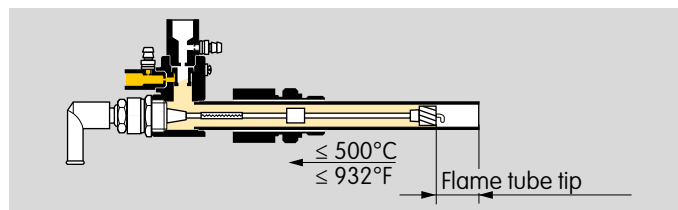

The tip of the ZMI flame tube or the ceramic flame tube of the ZMIC must not come into contact with the main burner flame. Safe ignition of the main burner must be ensured.

To avoid spontaneous combustion, the temperature of the gas/air mixture upstream of the tip of the flame tube must be lower than the ignition temperature of the fuel gas $\leq 500^{\circ}\text{C}$ (932°F).

When the pilot burner is switched off, the pilot burner air should continue to flow to ensure that the pilot burner is cooled.

5.2.1 ZMI in burner quarl

When pilot burners ZMI are installed in a burner quarl, the tip of the pilot burner is subjected to a very high thermal stress. A means of cooling the ZMI must always be provided. Air must constantly be passed through a 3 mm (0.12") gap on the outside of the flame tube. As a result of this measure, the service life of the pilot burners can be significantly increased.

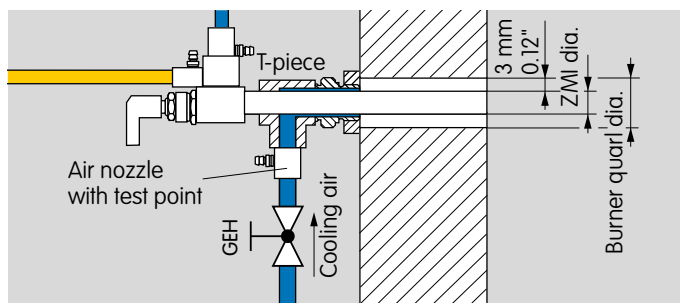

To adjust the cooling air volume, we recommend using the same air nozzles as for ZMI 16 (Ø 3.3 mm (0.13")) and ZMI 25 (Ø 4.5 mm (0.18")). The air pressure at the test point is set to approx. 20 to 25 mbar (7.9 to 9.8 "WC) using adjusting cock GEH.

5.2.2 ZMIC with bellows unit in burner quarl

When installing the ZMIC pilot burner in a burner quarl, it is recommended that the version with bellows unit be selected. The ceramic flame tube of the ZMIC must not be subjected to mechanical stress. To protect the metallic components from radiant heat, insulation of a thickness of approx. 140 mm must be fitted to the ceramic flame tube.

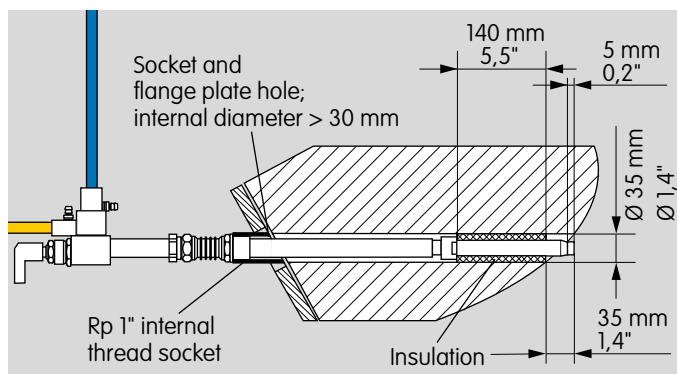

6 Accessories

6.1 Gas nozzle

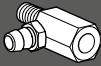

Burner	Gas type	Nozzle dia. [mm (inch)]	Order No.	
			ZMI/ZMIC	ZMI..T
ZMI 16	Natural gas	0.94 (0.037)	75455010	75442157
	LPG	0.76 (0.029)	75455147	75448032
	Town gas/coke oven gas	1.30 (0.051)	75455146	-
ZMI 25	Natural gas	1.40 (0.055)	75455012	75443157
	LPG	1.05 (0.041)	75455149	75448031
	Town gas/coke oven gas	1.78 (0.070)	75455148	-
ZMIC 28	Natural gas	1.40 (0.055)	75455012	-
	LPG	1.05 (0.041)	75455149	-
	Town gas/coke oven gas	1.78 (0.070)	75455148	-

6.2 High-voltage cable

For the ionization and ignition cables, use unscreened high-voltage cable:

FZLSi 1/7 -50 to 180°C (-58 to 356°F),
Order No. 04250410,

or

FZLK 1/7 -5 to 80°C (23 to 176°F),
Order No. 04250409.

6.3 Ignition transformer

To ensure safe ignition, we recommend using ignition transformer TGI 5-15/100W or TZI 5-15/100W.

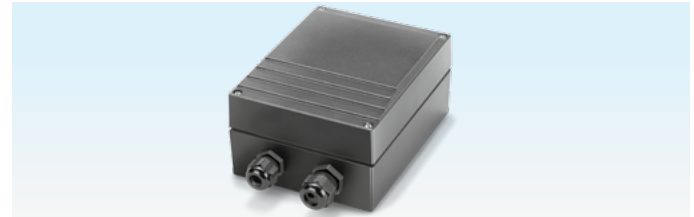

TGI 5-15/100W



TZI 5-15/100W

6.4 Regulator 60DJZ

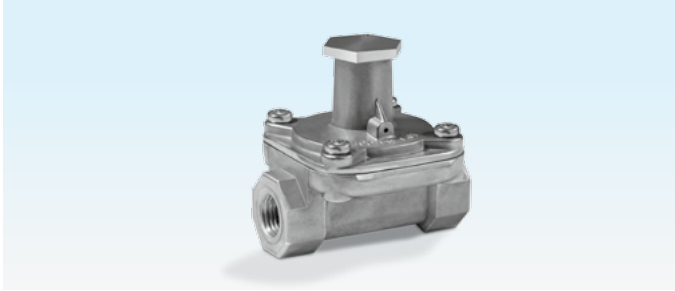

60DJZ, DN 8,
 Inlet pressure p_U : up to 100 bar,
 outlet pressure p_D : 35 – 90 mbar

6.5 Regulator J78R

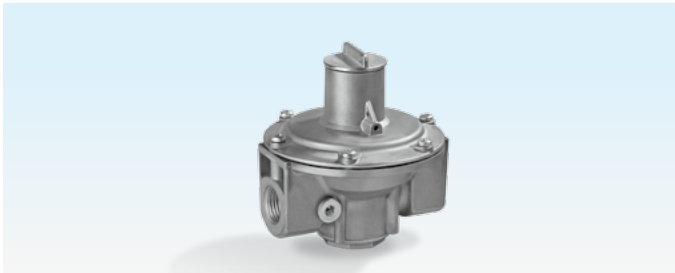

J78R, DN 15,
 Inlet pressure p_U : up to 100 bar,
 outlet pressure p_D : 42 – 55 mbar

	Gas	Order No.	Air	Order No.
ZMI 16	60DJZ	03155300	60DJLZ*	03155301
ZMI 25	60DJZ	03155300	J78R1-L*	03155026
ZMIC 28	60DJZ	03155300	J78R1-L*	03155026

* With special diaphragms for air operation

7 Technical data

Capacity:

ZMI 16: 1 to 2 kW (3.8 to 7.6 10³ BTU/h),

ZMI 25: 2.5 to 4 kW (9.5 to 15.1 10³ BTU/h)

(1.5 to 3.3 kW when used with town gas, coke oven gas),

ZMIC 28: 2.5 to 4.2 kW (9.5 to 15.9 10³ BTU/h).

Capacities in kW refer to the lower calorific value H_u and capacities in BTU/h refer to the upper calorific value H_o.

Gas inlet pressure:

ZMI: up to 80 mbar (up to 32 "WC),

ZMIC: up to 100 mbar (up to 40 "WC),

air inlet pressure: up to 120 mbar (up to 47 "WC),

each depending on the gas type.

Burner pressures: flow rate curves for ZMI, ZMIC, see www.docuthek.com → Elster Kromschröder

Search term: ZMI, ZMIC

Kind of document: Flow rate curves

Registration in the Docuthek required.

Burner length increments: 100 mm (4"),

length increments of the ZMIC 28..K: 50 mm (2").

Gas types: natural gas, LPG (gaseous) and coke oven gas; other gases on request.

For cold air only.

Flame control: with ionization electrode.

Ignition: direct spark ignition (5 kV ignition transformer).

Angle plug: interference-suppressed.

Housing: aluminium.

Flame tube:

ZMI: heat-resistant steel,

ZMIC: ceramic flame tube.

Max. temperature at the tip of the flame tube:

ZMI: 1000°C (1832°F),

for lambda < 1: 900°C (1652°F),

ZMIC: 1450°C (2642°F).

7.1 Dimensions

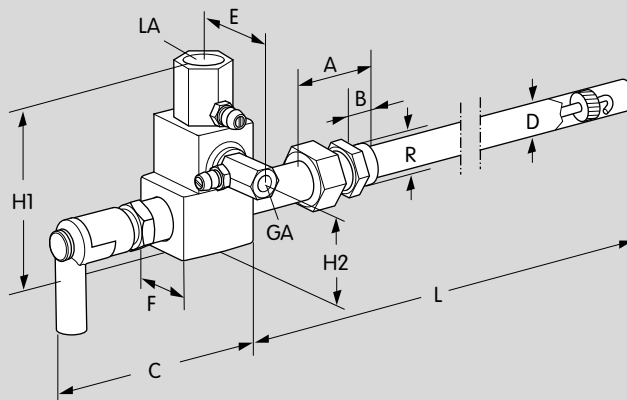

7.1.1 ZMI 16 and ZMI 25

Type	mm	Dimensions [mm]							ISO 7-1:1994		ISO 228-1
		D	A	B	C	E	F	H1	H2	GA	LA
ZMI 16	16	~44	13,5	~106	49	36	96	45	Rp 1/4	Rp 1/2	G 1/2
ZMI 25	25	~78	19	~112	49	36	96	45	Rp 1/4	Rp 1/2	G 1

* L = burner length increments: 150, 200, 300 ... mm (6, 8, 12 ... inches)

7.1.2 ZMI 16T and ZMI 25T

Type	inch	Dimensions [inch]									
		D	A	B	C	E	F	H1	H2	GA	LA
ZMI 16	0.63	1.73	0.56	4.17	2.64	1.42	3.78	1.77	1/4 NPT	1/2 NPT	1/2 NPT
ZMI 25	1	3.07	0.75	4.41	2.64	1.42	3.78	1.77	1/4 NPT	1/2 NPT	1 NPT

* L = burner length increments: 150, 200, 300 ... mm (6, 8, 12 ... inches)

7.1.3 ZMIC 28 without bellows unit

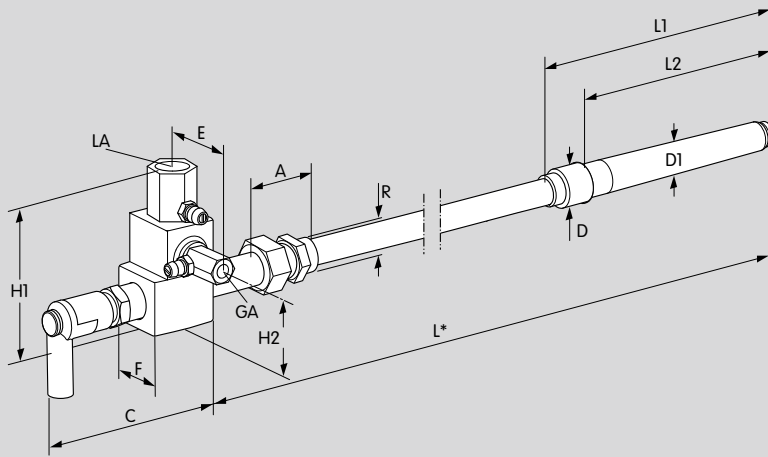

Type	Dimensions [mm]										ISO 7-1:1994		
	D	D1	A	C	E	F	L1	L2	H1	H2	GA	LA	R
ZMIC 28	28	19.5	~59.5	~106	49	36	203	173	96	45	Rp 1/4	Rp 1/2	R 1

* L = burner length increments: 100 mm.

7.1.4 ZMIC 28..K with bellows unit

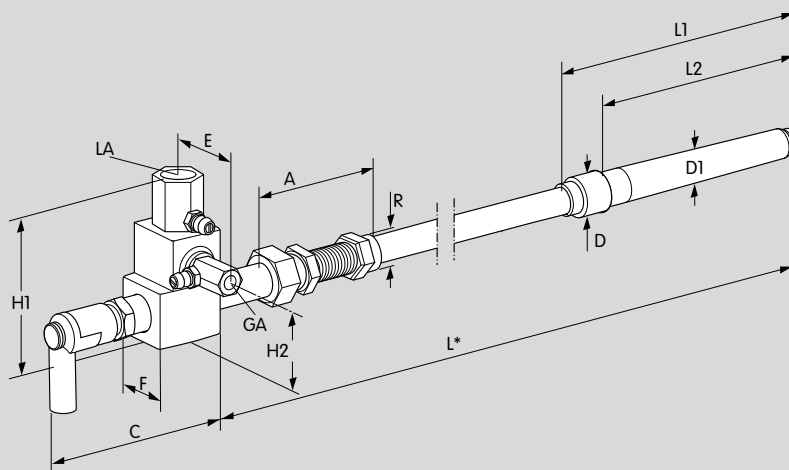

Type	Dimensions [mm]										ISO 7-1:1994		
	D	D1	A	C	E	F	L1	L2	H1	H2	GA	LA	R
ZMIC 28..K	28	19.5	~105	~106	49	36	203	173	96	45	Rp 1/4	Rp 1/2	R 1

* L = burner length increments: 50 mm.

7.2 Converting units

see www.adlatus.org/?sprache=1

8 Maintenance cycles

We recommend a function check at least once a year.

Feedback

Finally, we are offering you the opportunity to assess this “Technical Information (TI)” and to give us your opinion, so that we can improve our documents further and suit them to your needs.

Clarity

- Found information quickly
- Searched for a long time
- Didn't find information
- What is missing?
- No answer

Comprehension

- Coherent
- Too complicated
- No answer

Scope

- Too little
- Sufficient
- Too wide
- No answer



Use

- To get to know the product
- To choose a product
- Planning
- To look for information

Navigation

- I can find my way around
- I got “lost”
- No answer

My scope of functions

- Technical department
- Sales
- No answer

Remarks

Contact

Elster GmbH
Postfach 2809 · 49018 Osnabrück
Strothweg 1 · 49504 Lotte (Büren)
Germany

Tel +49 541 1214-0
Fax +49 541 1214-370
info@kromschroeder.com
www.kromschroeder.com

The current addresses of our international agents are available on the Internet:
www.kromschroeder.de/Weltweit.20.0.html?&L=1

We reserve the right to make technical modifications in the interests of progress.
Copyright © 2016 Elster GmbH
All rights reserved.

