

# *Eclipse Hermetic Gas Boosters*

*Series HB & HBLC  
Version 1.1*

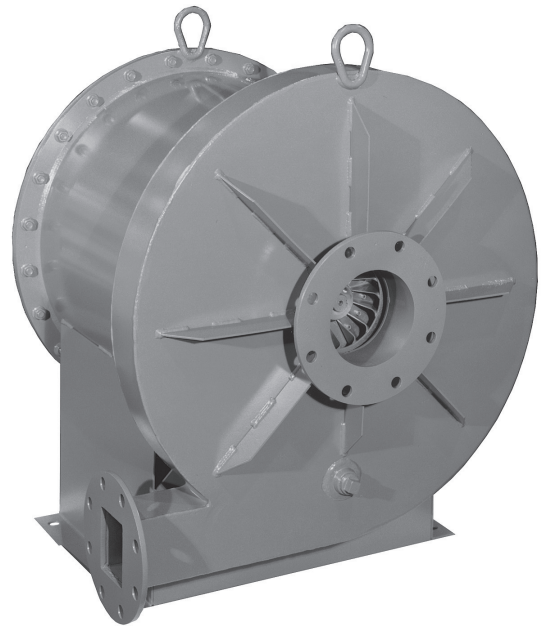
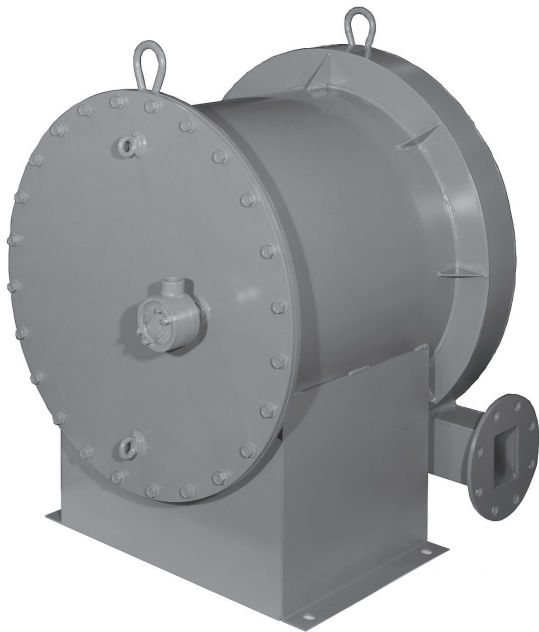

## Applications

Eclipse Inc., produces a line of single stage, centrifugal type, hermetically sealed gas boosters for use in piping systems for gases which are not corrosive to aluminum or steel. These gas boosters are used in applications where it is necessary to increase the line pressure above the available distribution system. They are designed and constructed to provide a volume of gas of a defined specific gravity (at standard temperature and pressure) compressed to a relatively constant pressure.

The hermetic gas booster is a self contained unit. It has a 3600 rpm synchronous speed, explosion proof motor which is UL listed for use in Class I, Group D hazardous locations. The impeller is mounted directly onto the motor shaft. The motor and fan are completely enclosed in a sealed steel casing which includes the wires in the conduit, to prevent gas from leaking into the surrounding environment. Electrical connections for the motor are made in a junction box mounted on the outside of the casing.

The discharge pressure is the total of the booster added pressure plus incoming gas pressure. Example: If the inlet pressure is 4" w.c. and the booster produces 14" w.c., then the outlet static pressure will be 18" w.c. The flow pressure curve for each booster is a function of the gas density, inlet and outlet diameters, impeller size (diameter and width) and motor rating. The outlet pressure varies throughout the gas flow range normally peaking at an intermediate flow then dropping off at the higher flow.

The volumetric flow is not affected by changes in the gas density but the pressure and horsepower consumed are as shown in the following equation:

$$\frac{D_2}{D_1} = \frac{SG_2}{SG_1} = \frac{P_2}{P_1} = \frac{HP_2}{HP_1}$$

D = Density, SG = Specific Gravity, P = Outlet Pressure, HP = Horsepower (consumed)

When incorporating a gas booster into a system, the use of a flow control device, such as a butterfly valve, is necessary to control the outlet flow to prevent the unit from exceeding the rated horsepower (current draw) of the motor. System designs should always include a pressure factor to ensure that adequate pressure will be available. Flow pressure curves should be used for reference if pressure margins are limited. Refer to **Datasheet 620** for specifications relating to application flow and turndown.

## Installation

### Location

Position the booster with respect to the service entrance as required by local codes or the authority having jurisdiction. Install booster in an accessible location on a level concrete floor or other substantial mounting pad.

Provide enough space between the booster terminal box and the nearest obstruction to allow removal of the internal assembly for maintenance purposes. The space required is shown in **Datasheet 620** as dimension "N".

### Level Housing

Be sure the top of the booster housing is level to avoid excessive wear of motor bearings.

### Bolting Booster to Base

Booster should be bolted to mounting pad through mounting holes provided in booster base. If desired, vibration pads may be installed under base.

If mounted rigid to mounting pad, avoid twisting the booster base when bolting down. Shim properly before tightening the mounting bolts.

## Piping

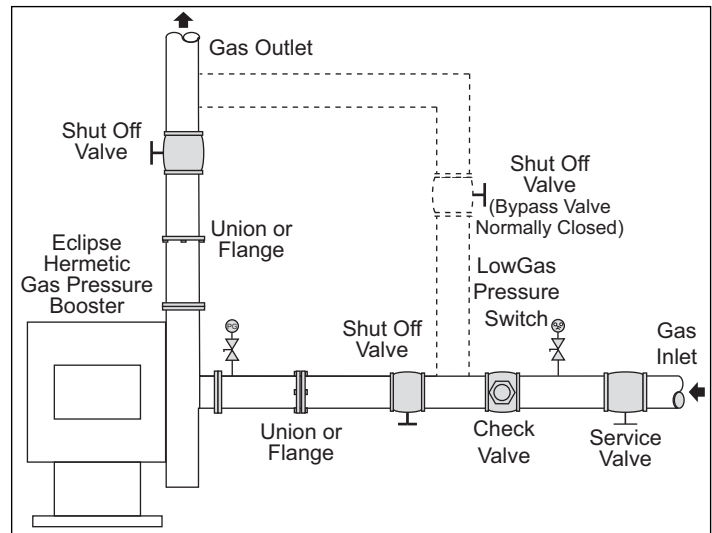

Figure 1. Typical Piping Arrangement

### Reduce Piping Bends

Hermetic boosters are available in various outlet positions so that a minimum number of piping bends is required. Bottom horizontal discharge and standard rotation, CCW as viewed from motor side, is supplied unless otherwise specified during ordering.

### Types of Piping and Fittings

Avoid pipe bends within 5 pipe diameters of the outlet. Use rigid piping to prevent gas leakage, excessive power consumption and possible power hazard. Use solid pipe connections, either threaded or flanged, at booster inlet and outlet. Check to insure that all fittings are tight and piping is not leaking.

### Piping Support

DO NOT use the booster to support piping. Use suitable brackets or hangers. Place the booster as close as possible to the appliance to minimize piping pressure losses.

### Low Gas Inlet Pressure

Local utilities typically require installation of a gas pressure switch on the inlet. It is used to prevent booster operation when the utility supply pressure is too low. The utility specifies the setting.

## Pipe Size

Use the appropriate pipe size from the booster to the appliance to avoid excessive pressure losses, see **Datasheet 620**. Avoid sharp bends and pipe constrictions.

## Test or Inlet Pressure

Inlet or test pressure must not exceed 5 psig.

## Electrical Characteristics

### Check Booster Nameplate

Before making any electrical connections, compare the electrical circuit characteristics to those of the motor to verify that they are the same. See specifications on the booster nameplate (see Figure 2 and Figure 3 for nameplate location).

### Meeting Electrical Codes

Local electrical codes and regulations covering motor starter, switches and controls vary. Have a certified electrical contractor install the proper switch or starter and make the necessary electrical connections.

## Protect the Motor

Premium efficiency motors are used on all Eclipse Hermetic gas boosters. They are UL listed Class 1, Group D and explosion proof. When wiring the booster motor, it is essential that it be properly protected against overload and excessive heat conditions (refer to Figure 4 for suggested wiring).

## Motor Starter Overload

Be certain that the motor starter overload protection is correct for power requirements.

## Verifying Fan Rotation

Be certain that the fan rotates properly so the blades travel towards the booster outlet. If necessary, remove the 1" rotation inspection plug from the booster end plate; momentarily start the motor and observe the fan rotation. Replace the rotation inspection plug after fan rotation has been determined (see Figure 2 and Figure 3 for rotation inspection plug location).

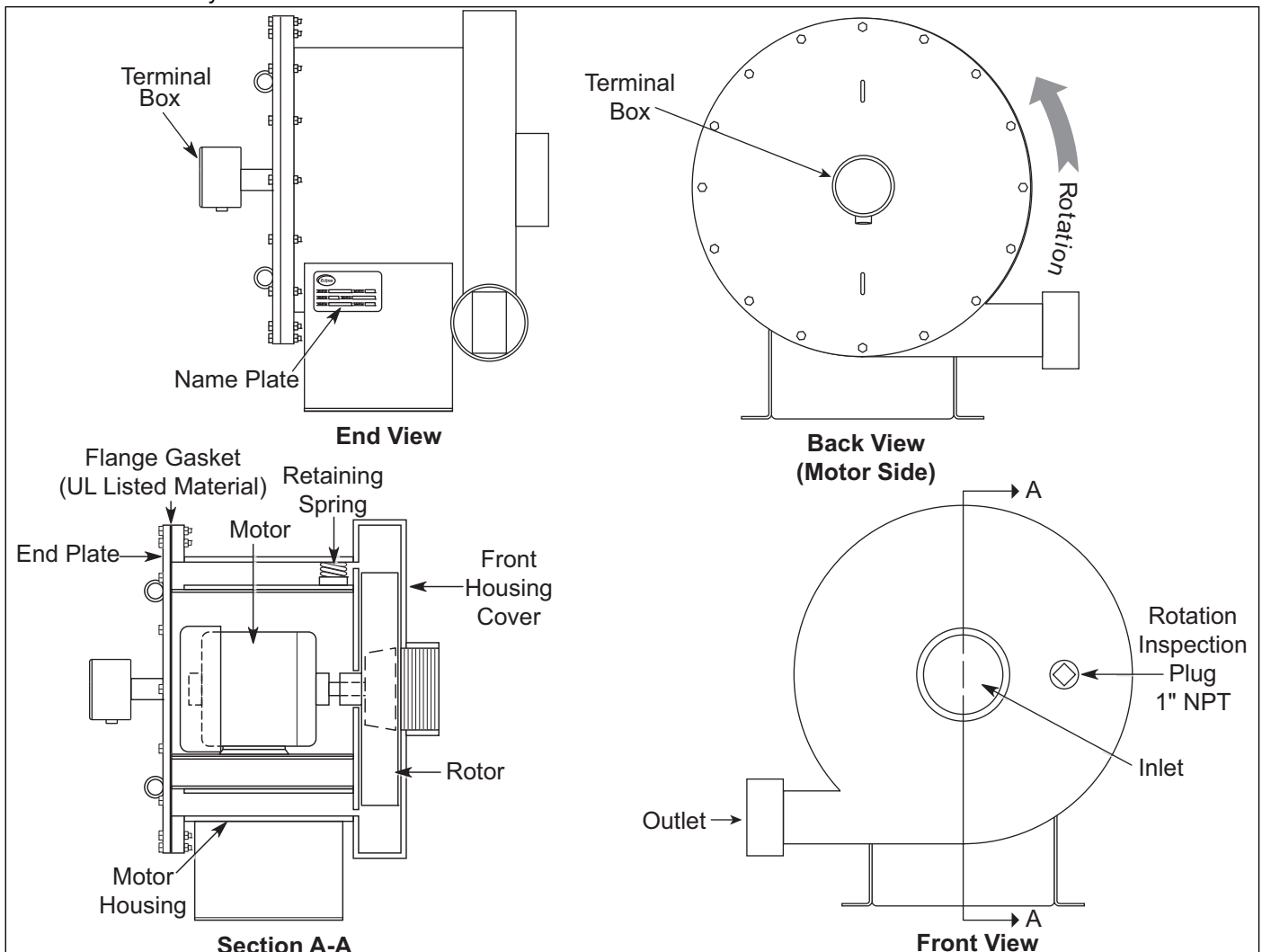

Figure 2. Parts Identification & Location - HB Series

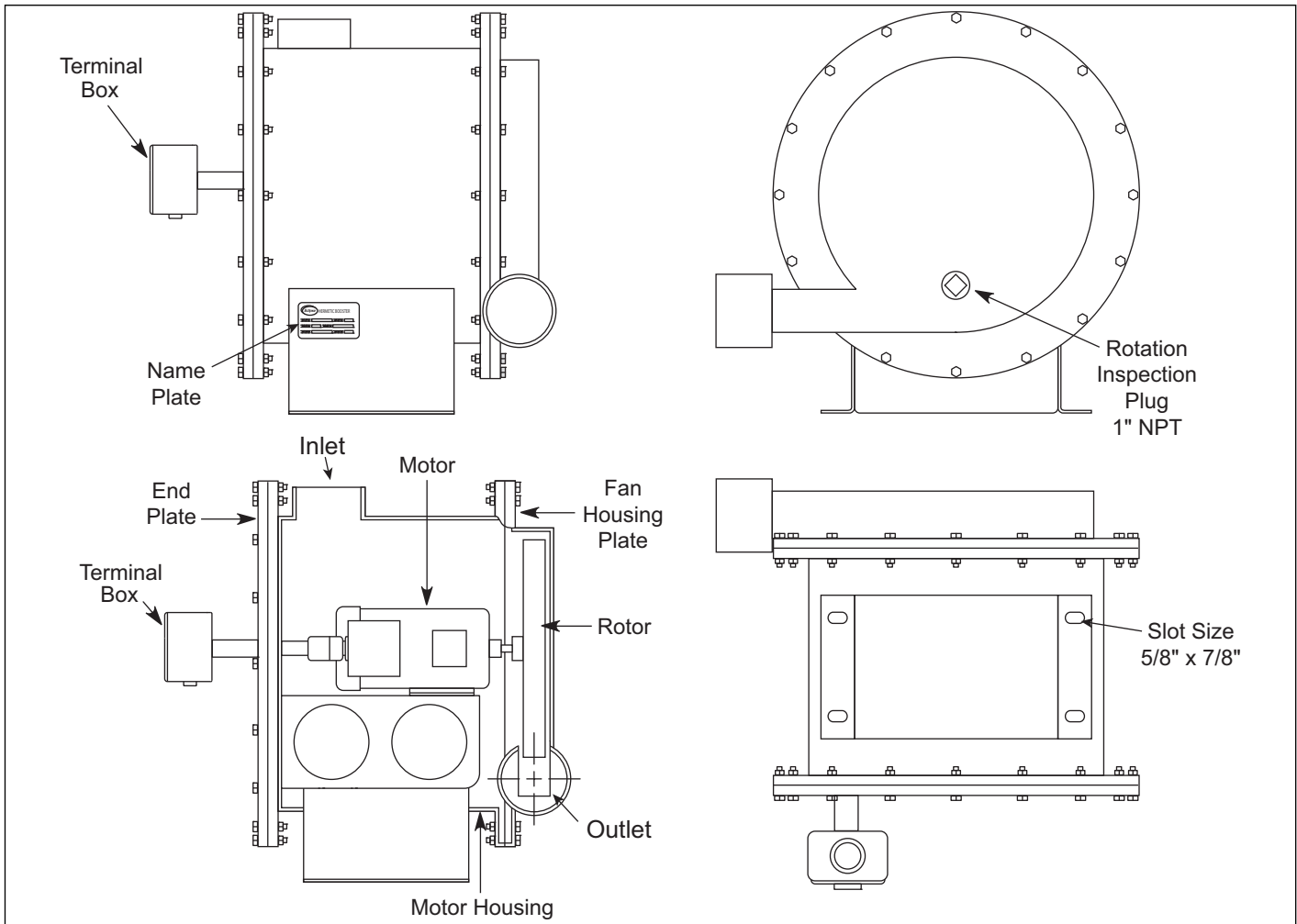

Figure 3. Parts Identification and Location - **HBLC Series**

## Maintenance

### Special Lubrication Requirement

NEMA Frame Size	Recommended Relubrication Intervals (hrs)	
	Up to 74°F Ambient	75 to 122°F Ambient or Corrosive Gas
Up to 180	*	*
Up thru 210	5500**	2750**
Over 210	3500**	1800**

\* These motors have sealed bearings which are factory lubricated for normal bearing life.

\*\* Motors with seasonal use (approximately 6 months) should be serviced at the beginning of the season.

**NOTE:** The motor bearings should be relubricated with either Dow Corning FS-3451 silicone grease or Christo-Lube MCG-134 grease (#2 consistency) at the intervals noted in the above table. Motor lubrication is identified on a tag attached adjacent to the booster ID tag. Motors lubricated with Christo-Lube are also identified on the motor nameplate. Relubrication can be done on-site or at any authorized Baldor® Service Center. Be certain to identify the correct grease to the service center. Contact

Lubrication Technology Inc., at (800) 477-8704 for Christo-Lube MCG-134 grease. Reference use in Baldor motors when ordering. Grease is available in 1 lb containers (approximately 8 fluid ounces).

### Removing the Internal Assembly

Motor and rotor are easily accessible by unbolting the end plate and sliding the entire motor and rotor assembly out of the housing. On the HBLC-3316-3/4 Booster, you must unbolt end plate and fan housing plate, remove set screws on rotor with long handled socket tool, remove the rotor, and then slide motor assembly out.

The entire internal assembly is easily removed from the booster for motor and rotor inspection and/or maintenance.

**NOTE:** To ensure that the booster is properly sealed when reassembled, a spare flange gasket should be ordered and used (refer to the table for ordering information).

To remove the internal assembly, use the following procedures (see Figure 2 and Figure 3 for part identification):

- Be certain that the gas, air and electricity are shut off before disassembly.

- Remove end plate bolts. For the HBLC also remove the fan housing bolts, set screws and rotor. Carefully slide out entire internal assembly. Be careful not to damage or upset rotor balance.
- DO NOT disturb wiring conduit or terminal box position as this will break the gas seal and result in gas leakage.
- When reassembling the internal assembly, install a new flange gasket.

Uncut Gasket Ordering Information		
Part Number	Amount Needed (Sq. Ft.)	Fan Diameter (Inches)
38005	4	up to 15
38005	9	17 or over

Pre-Cut Gasket Ordering Information		
HB Model	Part Number	Quantity
HB-3412-1/2	14093	1
HB-4412-1/2	14093	1
HB-4412-1	14093	1
HB-3314-1/2	14093	1
HB-4414-1	14093	1
HB-4614-1	14019	1
HB-4614-1-1/2	14019	1
HB-4615-1	14019	1
HB-6615-1-1/2	16800	1
HB-6615-2	16800	1
HB-4617-1	13823	1
HB-4617-1-1/2	13823	1
HB-6617-2	13823	1
HB-6617-3	14793	1
HB-8817-5	16558	1
HB-4619-1-1/2	14222	1
HB-4619-2	14222	1
HB-6619-3	14222	1
HB-6619-5	17959	1
HB-8819-7-1/2	15353	1
HB-8819-10	15353	1
HB-4623-3	16558	1
HB-4623-5	16558	1
HB-6623-7-1/2	14377	1
HB-6623-10	14377	1
HB-8823-15	14377	1
HB-8823-20	14377	1
HB-4628-5	13734	1
HB-4628-7-1/2	13734	1
HB-4628-10	13734	1
HB-8828-10	13734	1
HB-8828-15	13734	1
HB-8828-20	13734	1
HB-LC-3316-3/4	14549	2

## Relubrication Procedure

- Applicable for 3 Hp and larger motors lubricated with Christo-Lube MCG-134 grease only. Motors 2 Hp and smaller have sealed bearings which are factory lubricated for normal bearing life. Motors with Dow Corning FS-3451 grease do not contain grease fittings.
- Clean the grease fittings.
- Remove the grease outlet plugs.
- Add recommended amount of Christo-Lube MCG-134 grease. Stop when new grease appears at the shaft hole in the end plate or at the outlet plug hole. Approximate grease amounts for each bearing are:
  - .33 fluid oz. for 3 to 5 Hp motors (up to 210 NEMA frame)
  - .66 fluid oz. for 7.5 Hp and larger motors (over 210 NEMA frame)
- Clean up excess grease and replace outlet plugs.

## Storage and Shutdown

The following recommendations will minimize potential damage to equipment when the unit will not be operating for long periods or when the unit will be put into storage:

1. Inspect the booster for external damage, paint chips, damaged seals, and repair as required.
2. Lubricate the motor bearings if the unit has operated more than half of the recommended time interval specified in "Maintenance".
3. Guard against corrosive elements contained within the hermetic volume of the booster.
  - If the booster is removed from the piping system, insure that the contained volume is dry and inert and then seal off both the inlet and outlet.
  - In the case where a booster system has been operating on clean dry natural gas and will not be removed, simply close the inlet and outlet valves to isolate any moisture incursions.
  - In the case of gas with corrosive content, such as hydrogen sulfide in natural gas, then the hermetic volume must be purged with a dry inert gas before sealing.
4. When putting the system back into operation, the motor insulation integrity should be tested with a "Megger Insulation Tester", and the bearings must be relubricated.

## Problems or Questions

Call your local Eclipse office for any required assistance or for recommended spare parts.

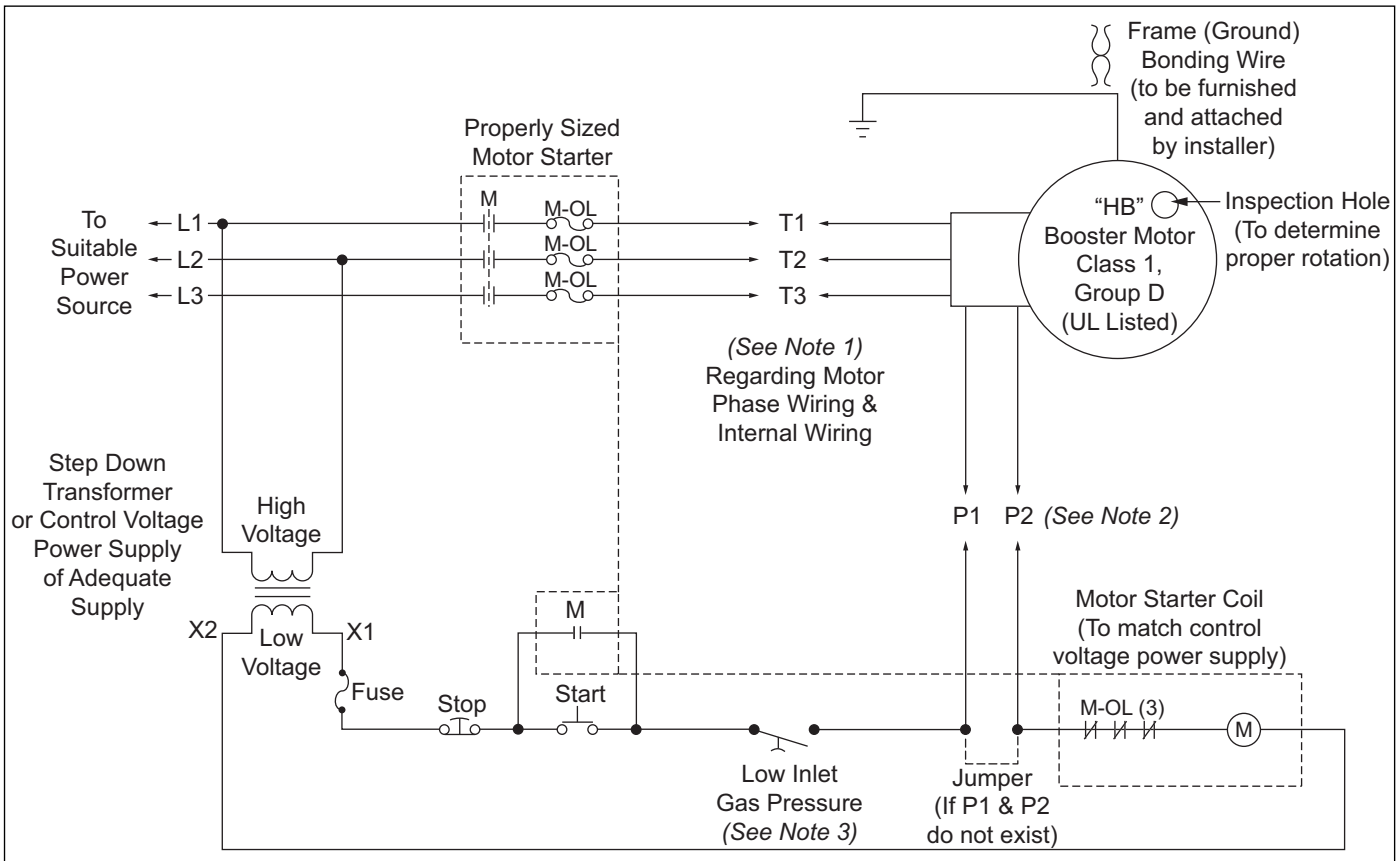

Figure 4. Suggested Wiring

## Notes:

### 1. Motor Phase Wiring

*For three phase:* Three black wires for T1, T2 & T3.

*For 115V, single phase:* One black wire to T1 and one white wire to T2.

*For 230V, single phase:* One black wire to T1 and one red wire to T2.

### Internal Wiring of "HB" Booster

Eclipse will internally wire only the HB Booster for the customer specified voltage and bring out the minimum number of necessary connecting wires to a termination box.

### 2. P1 and P2 Wires

Two red wires labeled "P1" and "P2" are normally closed thermostat wires that will open when the motor winding temperature rises above its design limit. The "M" motor starter will de-energize. It is the customer's responsibility to wire "P1" or "P2" into any control circuit as shown. **The "P1" and "P2" wires do not exist on some motors, such as 1/2 Hp, 3/4 Hp, and special ordered types. Without these, the circuit must be wired with the jumper.**

### 3. Inlet Gas Pressure Switch

Low inlet gas pressure switch closes when the inlet gas pressure is above the minimum acceptable pressure specified by the local utility company.

### 4. Wiring Standards

All wiring and installation must conform with national and local electrical codes. All of the booster's external wiring and wiring of the equipment is the customer's responsibility unless otherwise specified.