

Eclipse Linnox Burners

Models Straight ULE and Tee ULE

Technical Information Edition 6.15

Version 1

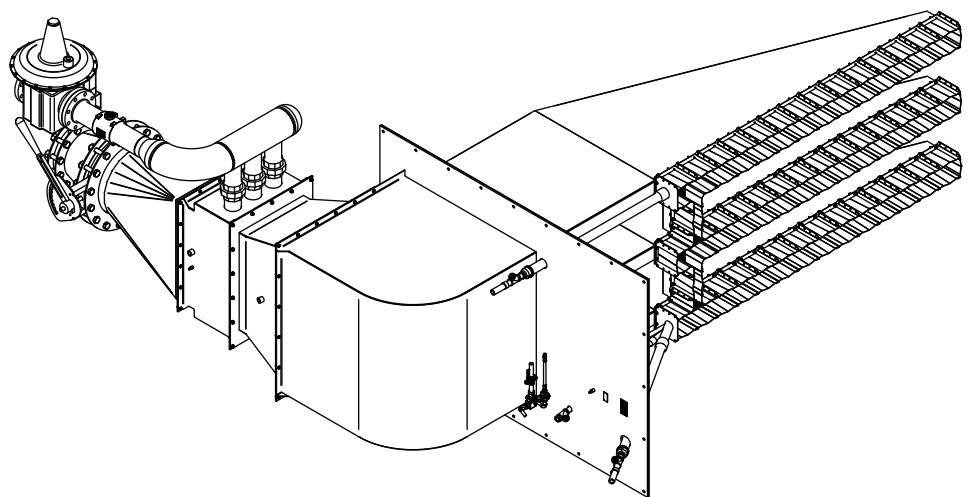
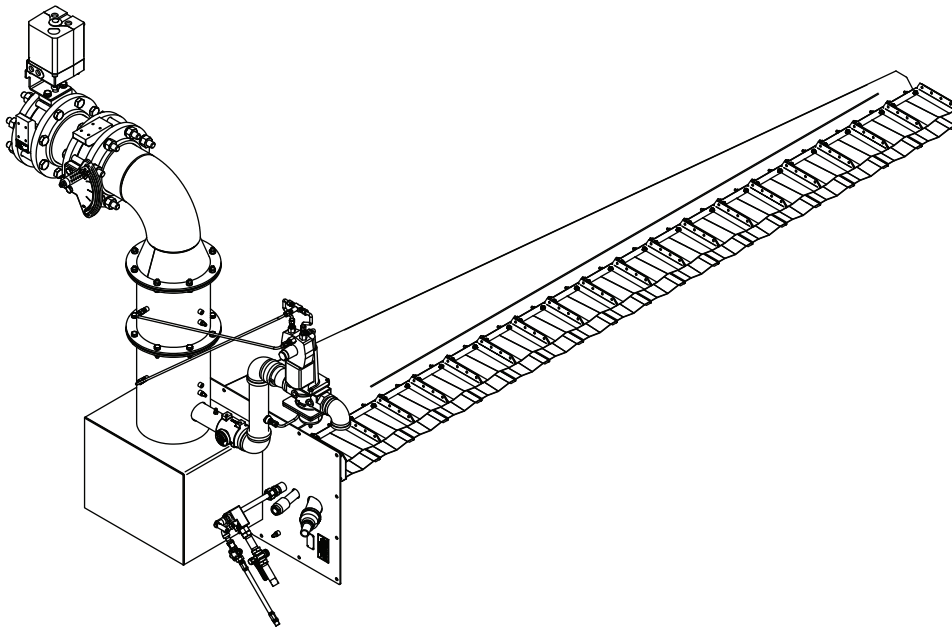

Copyright

Copyright 2011 by Eclipse, inc. All rights reserved worldwide. This publication is protected by federal regulation and shall not be copied, distributed, transmitted, transcribed or translated into any human or computer language, in any form or by any means, to any third parties, without the express written consent of Eclipse, inc.

Disclaimer Notice

In accordance with the manufacturer’s policy of continual product improvement, the product presented in this brochure is subject to change without notice or obligation.

The material in this manual is believed adequate for the intended use of the product. If the product is used for purposes other than those specified herein, confirmation of validity and suitability must be obtained. Eclipse warrants that the product itself does not infringe upon any United States patents. No further warranty is expressed or implied.

Liability & Warranty

We have made every effort to make this manual as accurate and complete as possible. Should you find errors or omissions, please bring them to our attention so that we may correct them. In this way we hope to improve our product documentation for the benefit of our customers. Please send your corrections and comments to our Technical Documentation Specialist.

It must be understood that Eclipse’s liability for its product, whether due to breach of warranty, negligence, strict liability, or otherwise is limited to the furnishing of replacement parts and Eclipse will not be liable for any other injury, loss, damage or expenses, whether direct or consequential, including but not limited to loss of use,

income, or damage to material arising in connection with the sale, installation, use of, inability to use, or the repair or replacement of Eclipse’s products.

Any operation expressly prohibited in this manual, any adjustment, or assembly procedures not recommended or authorized in these instructions shall void the warranty.

Document Conventions

There are several special symbols in this document. You must know their meaning and importance.

The explanation of these symbols follows below. Please read it thoroughly.

How To Get Help

If you need help, contact your local Eclipse representative. You can also contact Eclipse at:

1665 Elmwood Rd.
 Rockford, Illinois 61103 U.S.A.
 Phone: 815-877-3031
 Fax: 815-877-3336
<http://www.eclipsenet.com>

Please have the information on the product label available when contacting the factory so we may better serve you.

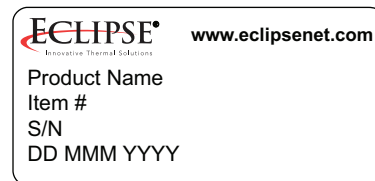

This is the safety alert symbol. It is used to alert you to potential personal injunt hazards. Obey all safety messages that follow this symbol to avoid possible injury or death.



Indicates a hazardous situation which, if not avoided, will result in death or serious injury.



Indicates a hazardous situation which, if not avoided, could result in death or serious injury.



Indicates a hazardous situation which, if not avoided, could result in minor or moderate injury.

NOTICE

Is used to address practices not related to personal injury.

NOTE

Indicates an important part of text. Read thoroughly.



Table of Contents

1 Introduction	4
Product Description	4
Audience	4
Purpose	4
Linnox Straight ULE and Tee ULE Documents	4
Related Documents	4
2 Safety	6
Introduction	6
Safety Warnings	6
Capabilities	6
Operator Training	6
Replacement Parts	6
3 System Design	7
Design	6
Step 1: Burner Option Selection	6
Step 2: Blower Design	8
Step 3: Control Methodology	9
Step 4: Ignition System	10
Step 5: Flame Monitoring Control System	11
Step 6: Main Gas Shut-Off Valve Train	11
Step 7: Process Temperature Control System	12
Step 8: Process Air Duct Design	12
Appendix	i
Key to System Schematics	ii
Notes	iv

Introduction

1

Product Description

The Linnox is a line model burner designed for applications where a maximum linear heat distribution is required.

The Linnox burner is a pre-mix type burner, designed for direct-air heating applications where the lowest achievable NO_x and CO levels are required.

Linnox combustion is based on high excess air, pre-mix combustion to keep the flame temperatures low. At the same time, the burner geometry establishes an internal recirculating flame pattern. These two factors result in ultra low NO_x and CO emissions across the turndown range while maintaining extremely stable combustion.

This burner can be easily configured for many different capacities by choosing from a wide range of burner modules each 300 mm in length.

The Linnox is designed to provide:

- Reliable operation
- Simple adjustments
- Efficient ratio controlled combustion
- Burner modules varying from 90 to 2700 kBTU/h (26 to 791 kW per 300 mm).

Purpose

The purpose of this manual is to ensure an appropriate burner selection for your application.

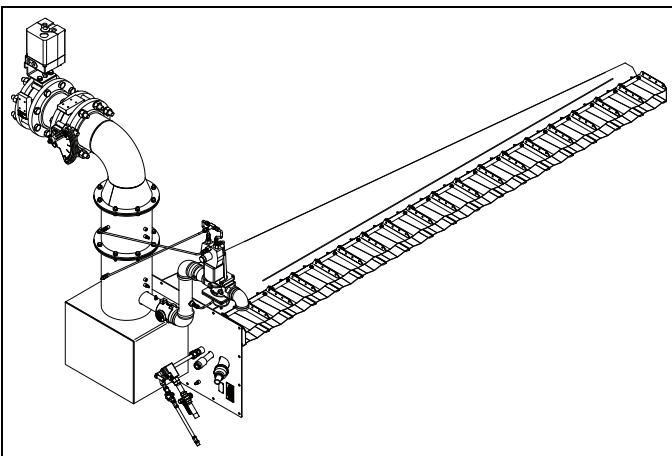

Figure 1.1 Linnox Straight ULE Burner

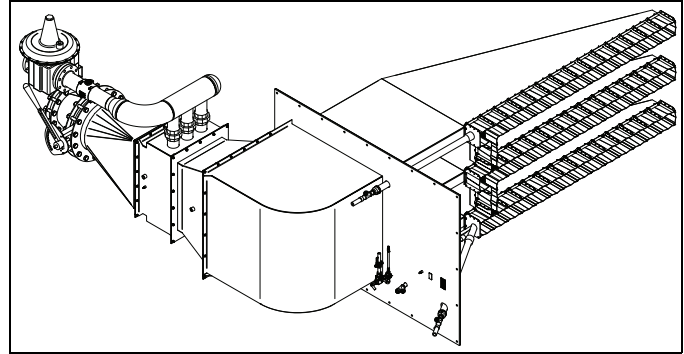

Figure 1.2 Linnox Tee ULE Burner

Audience

This manual has been written for personnel already familiar with all aspects of pre-mix burners.

These aspects include:

- Design/Selection
- Use
- Maintenance
- Safety

The audience is expected to be qualified and have experience with this type of equipment and its working environment.

Linnox Straight ULE and Tee ULE Documents

Design Guide 159

- This document

Datasheet Series 159

- Required to complete design and selection

Installation Guide 159

- Used with datasheet to complete installation

Worksheet 159

- Required to provide application information to Eclipse Engineering

Spare Parts List Series 159

- Recommended replacement part information

Related Documents

- EFE 825 (Combustion Engineering Guide)
- Eclipse Bulletins and Information Guides: 610, 710, 720, 730, 742, 744, 760, 930

Safety

2

Important notices which help provide safe burner operation will be found in this section. To avoid personal injury and damage to the property or facility, the following warnings must be observed. All involved personnel should read this entire manual carefully before attempting to start or operate this system. If any part of the information in this manual is not understood, contact Eclipse before continuing.

Safety Warnings



DANGER

- **The burners, described herein, are designed to mix fuel with air and burn the resulting mixture. All fuel burning devices are capable of producing fires and explosions if improperly applied, installed, adjusted, controlled or maintained.**
- **Do not bypass any safety feature; fire or explosion could result.**
- **Never try to light a burner if it shows signs of damage or malfunction.**



WARNING

- **The burner and duct sections are likely to have HOT surfaces. Always wear the appropriate protective equipment when approaching the burner.**
- **Eclipse products are designed to minimize the use of materials that contain crystalline silica. Examples of these chemicals are: respirable crystalline silica from bricks, cement or other masonry products and respirable refractory ceramic fibers from insulating blankets, boards, or gaskets. Despite these efforts, dust created by sanding, sawing, grinding, cutting and other construction activities could release crystalline silica. Crystalline silica is known to cause cancer, and health risks from the exposure to these chemicals vary depending on the frequency and length of exposure to these chemicals. To reduce the risk, limit exposure to these chemicals, work in a well-ventilated area and wear approved personal protective safety equipment for these chemicals.**

NOTICE

- **This manual provides information regarding the use of these burners for their specific design purpose. Do not deviate from any instructions or application limits described herein without written approval from Eclipse.**

Capabilities

Only qualified personnel, with sufficient mechanical aptitude and experience with combustion equipment, should adjust, maintain or troubleshoot any mechanical or electrical part of this system. Contact Eclipse for any needed commissioning assistance.

Operator Training

The best safety precaution is an alert and trained operator. Train new operators thoroughly and have them demonstrate an adequate understanding of the equipment and its operation. A regular retraining schedule should be administered to ensure operators maintain a high degree of proficiency. Contact Eclipse for any needed site-specific training.

Replacement Parts

Order replacement parts from Eclipse only. All Eclipse approved valves or switches should carry UL, FM, CSA, CGA and/or CE approval where applicable.

System Design

3

Design

The design process is divided into the following steps:

1. **Burner Model / Size Selection:**
2. **Blower Design:**
3. **Control Methodology:**
4. **Valve Train Design:**
5. **Process Air Duct Design:**

Step 1: Burner Option Selection

Step 1 describes how to select burner options to suit an application. Use Worksheet 159 and Datasheets 159-1 and 159-2 when following this selection process.



- **Consult EFE-825 Eclipse Engineering Guide or contact Eclipse if you have special conditions or questions.**

Burner Model / Size Selection

Consider the following when selecting the burner size:

- **Heat Input:** Calculate the required heat input to achieve the required heat balance.
- **Burner Length:** Define the necessary burner length. The burner consists of modules of 1 ft (300 mm) in length, so the length of the burner must be a multiple of 1 ft (300 mm). The maximum standard length is 9 ft (2700 mm). Longer burners are available as engineered orders. The duct size must be determined, before defining the burner length.
- **Number of Rows:** Define the number of burner rows required. The maximum number of rows is four. The duct size must be determined before defining the number of burner rows.
- **Input per Module:** The design of the burner is flexible and multiple inputs per module are available. Calculate the heat input per module and then select one of the applicable modules.
Select a module which is closest to the calculated heat input per module. The exact input per module will probably not match the calculated value. To achieve the required total heat input, the next higher module must be selected. Refer to the datasheet to determine the correct module.
- **Turndown:** Turndown is available in 10:1 or 8:1 options. Selection is based on system requirements.
- **Fuel Type:** Variation in calorific value and density will affect burner performance. Nominal burner performance is based on fuel properties in Fuel Type table below.
- **Flame Supervision:** The only flame supervision device available for the Linnox is a UV Scanner.
- **Mounting Plate:** Mounting plates are designed for mounting to an opening in the process air ducting. The mounting plate is manufactured from metal plate and is painted with a heat resistant coating on the mounting side. Mounting plate dimensions vary due to total input and duct spacing. Two options are available, non-insulated and insulated. The insulated option is 3.9 inch (100 mm) thick.
- **Duct Spacing:** The burner can be positioned in the duct with the duct spacing dimension, as shown in Figure 3.3 on page 9. The dimension can be selected from 7.9 - 39.4 inches (200 - 1000 mm) in 3.9 inch (100 mm) increments.
- **Air and Gas Inlet Orientation:** The burner can be provided with air and gas inlet positions as shown in Figures 3.1 and 3.2 on page 8.

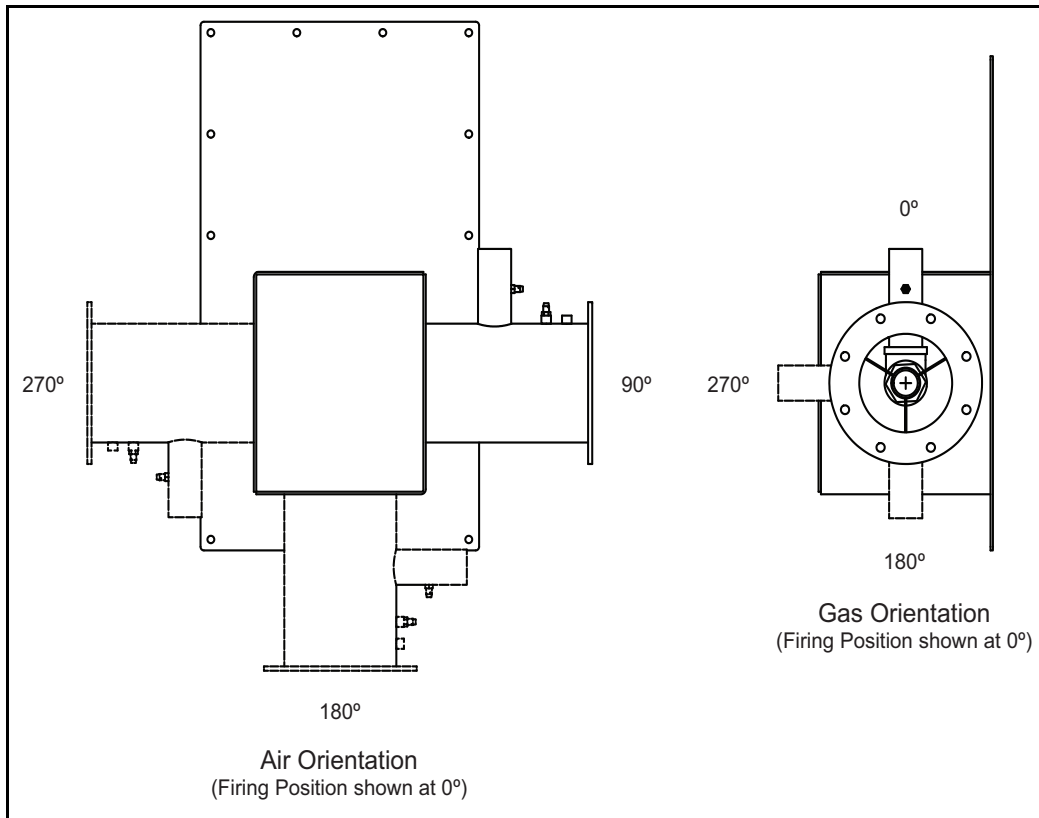

Figure 3.1 Straight ULE Air and Gas Inlet Orientations

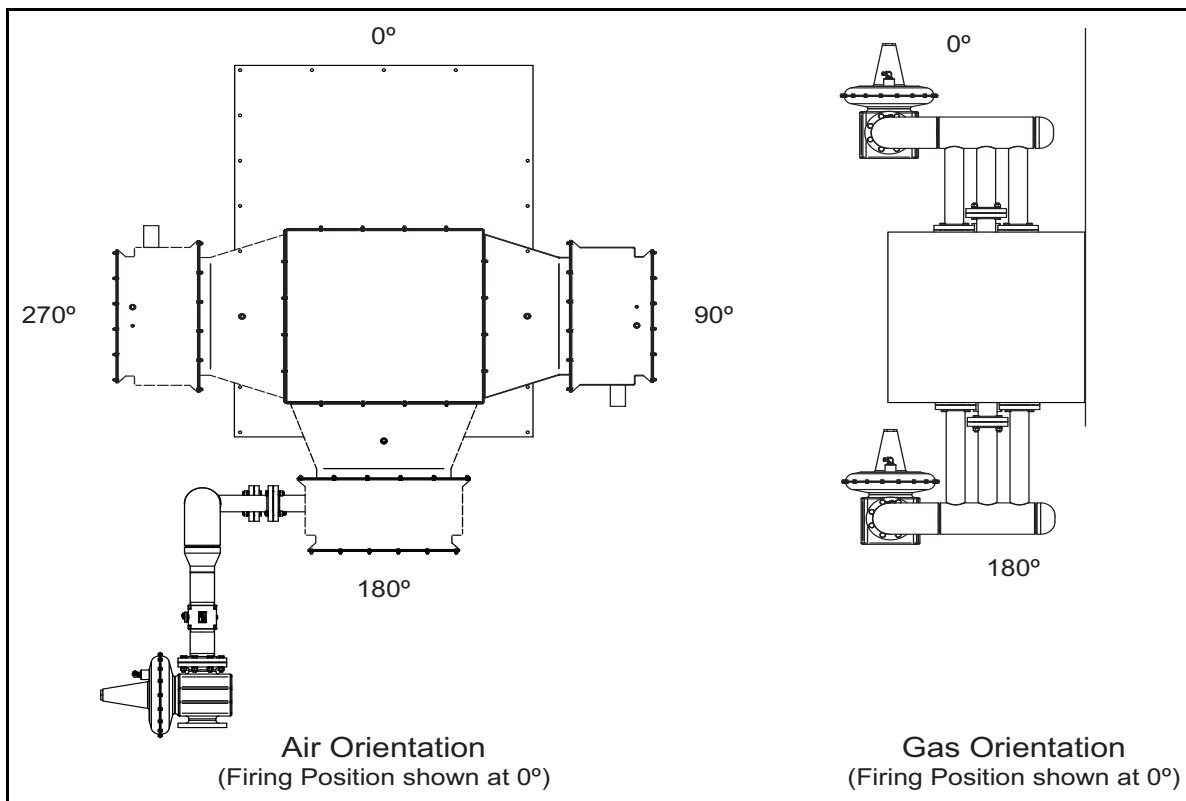

Figure 3.2. Tee ULE Air and Gas Inlet Orientations

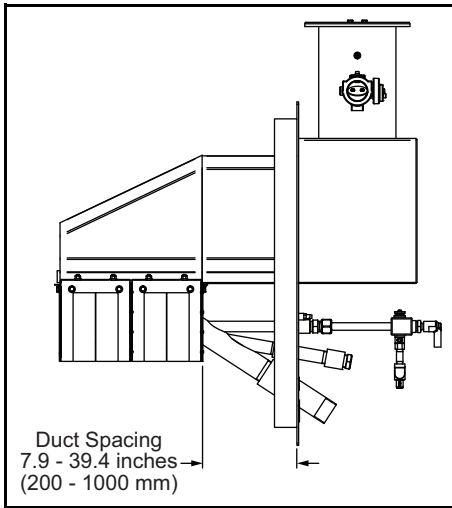

Figure 3.3. Duct Spacing Options

Step 2: Blower Design

Pressure & Flow

The Linnox Straight ULE and Tee ULE burners are designed for 20 "w.c. (50 mbar) of combustion air pressure at the burner inlet at maximum input. This applies regardless of module or length. Both the process air pressure and pressure losses due to the piping from blower to burner need to be added to that 20 "w.c. (50 mbar).

The flow of combustion air, however, is dependent on the capacity of the burner. The burner operates with 40% excess air. The total flow is calculated as follows:

$$\text{Airflow (SCFH)} = \text{Gasflow (SCFH)} \times \text{stoichiometric air requirement (SCF air / SCF gas)} \times 1.4.$$

Or

$$\text{Airflow (m}^3\text{/h)} = \text{Gasflow (m}^3\text{/h)} \times \text{stoichiometric air requirement (m}^3\text{ air / m}^3\text{ gas)} \times 1.4$$

Fuel Type

Fuel	Symbol	Gross Heating Value	Specific Gravity	WOBBE Index
Natural Gas	CH ₄ 90%+	1000 Btu/ft ³ (40.1 MJ/m ³)	0.60	1290 Btu/ft ³

Btu/ft³ @ standard conditions (MJ/m³ @ normal conditions)

If using an alternative fuel supply, contact Eclipse with an accurate breakdown of the fuel components.

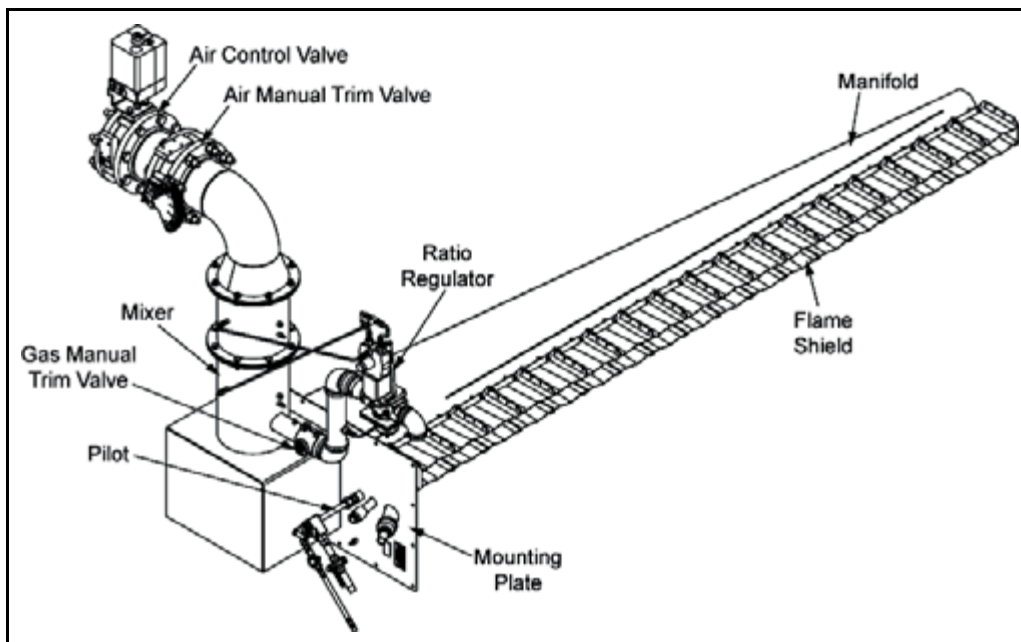

Figure 3.4. Straight ULE Component Identification

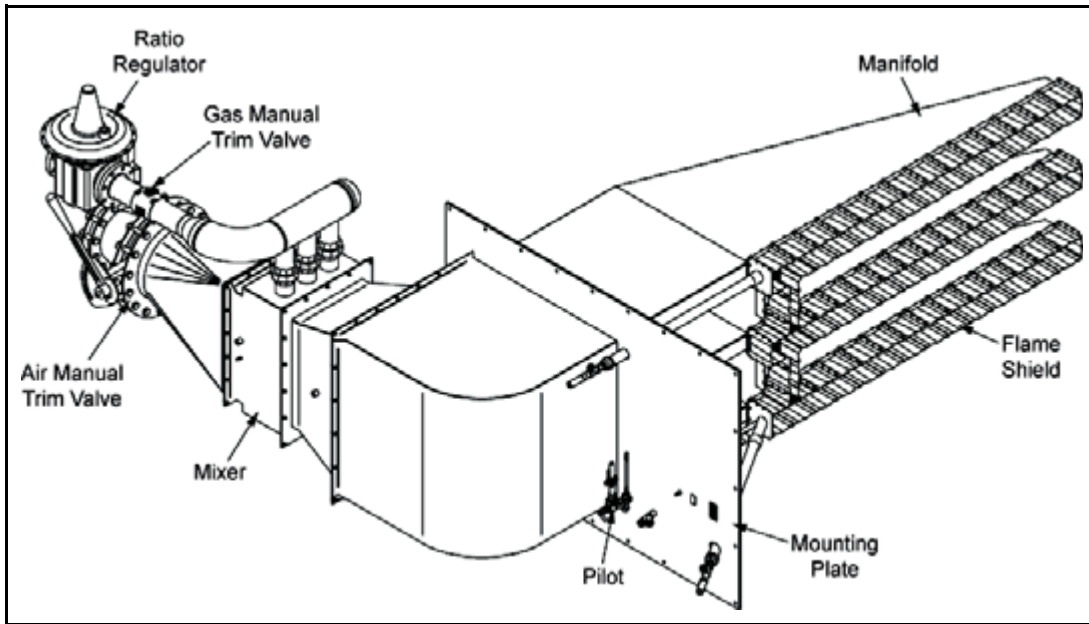

Figure 3.5. Tee ULE Component Identification

Step 3: Control Methodology

Gas/Air Ratio

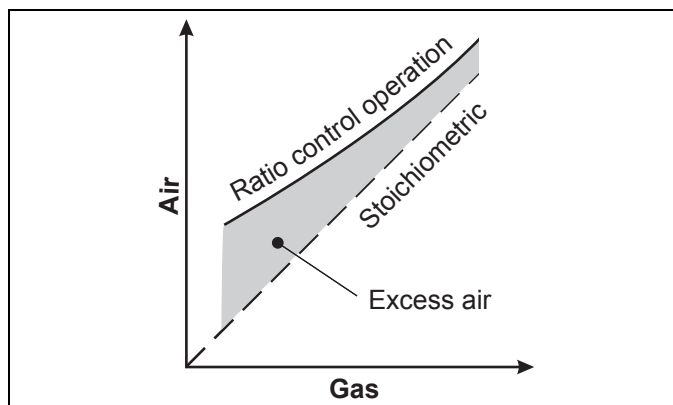

Figure 3.6. Air : Gas Flow

The gas/air ratio is critical for the Linnox burner. All standard Linnox burners are designed for air:gas ratio controlled combustion. The gas/air ratio should remain constant with lambda 1.4, 40% excess air, over the full turndown.

Deviation from this gas/air ratio is not suggested. At lambda 1.3, 30% excess air, the burner may be damaged by overheating. If lambda is higher than 1.5, 50% excess air, the flame will blow off.

To maintain the proper air/gas ratio, the Eclipse-supplied ratio control device must be used.

Burner Control

Linnox burners come with a ratio regulator that maintains the air:gas ratio, see Figure 3.6 above. The burner control signal drives the air actuator.

A control signal is sent from a process temperature controller (sold separately) to the control actuator. (Refer to Bulletin 818C or contact Eclipse for further information on temperature controllers.)

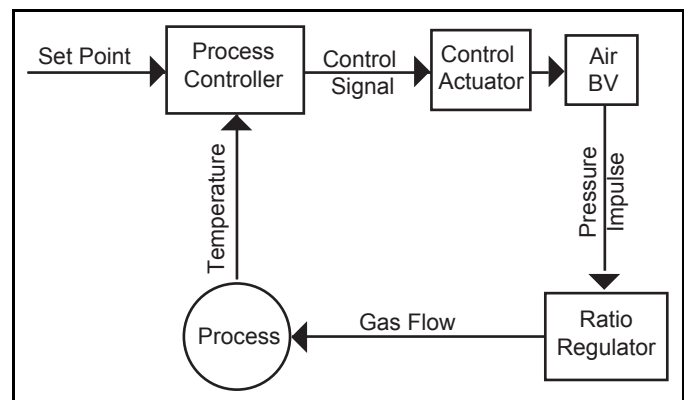

Figure 3.5. Basic Control Loop

- The control actuator modulates the air butterfly valve (BV) which controls the combustion air flow.
- Air pressure in the burner mixer box sends an impulse in the loading line to the ratio regulator.
- The ratio regulator controls the gas flow in proportion to the air flow.

**WARNING**

- **Do not use other control methods, such as fixed-air control, or alter the ratio regulator or burner piping without prior approval from Eclipse.**

Step 4: Ignition System**Ignition Transformer**

For the ignition system, use a transformer with:

- secondary voltage 6,000 to 8,000 VAC
- minimum secondary current 0.02 amps
- full wave output

DO NOT USE the following types of transformers:

- twin outlet
- distributor type
- electronic type

Trial for Ignition

It is recommended that ignition at 30% of input be used.

Most local safety codes and insurance requirements limit the maximum trial for ignition time (the time it takes for a burner to ignite). These requirements vary from one location to another; check your jurisdictional codes and comply to the strictest codes applicable.

The time it takes for a burner to ignite depends on the following:

- the distance between the gas shut-off valve and the burner
- the air:gas ratio
- the gas flow conditions at start-up

The possibility exists where the low fire settings are insufficient to ignite the burner within the maximum trial for ignition time. The following options must be considered under these conditions:

- start at higher gas input levels
- resize and/or relocate the gas controls

Step 5: Flame Monitoring Control System

The flame monitoring control system consists of two main components:

- Flame Sensor
- Flame Monitoring Control

Flame Sensor

A UV scanner is the only type of flame sensor that can be used on a Linnox burner.

The UV scanner must be compatible to the flame monitoring control that is used. Refer to the manual of your selected control for proper selection of the UV scanner.

Flame Monitoring Control

The flame monitoring control is the equipment that processes the signal from the flame sensor and controls the start-up and shut-down sequences.

For flame monitoring control you may select several options:

- flame monitoring control for each burner: if one burner goes down, only that burner will be shut off
- multiple burner flame monitoring control: if one burner goes down, all burners will be shut off

Eclipse recommends the following flame monitoring controls:

- Trilogy series T600 (modulating); see Instruction Manual 835
- Trilogy series T600 and FLW411 (two UV scanners); see Instruction Manual 835
- Veri-Flame series 5600: see Instruction Manual 818
- Bi-Flame series 6500: see Instruction Manual 826

NOTICE

- **If other controls are considered, contact Eclipse to determine how burner performance may be affected. Flame monitoring controls that have lower sensitivity flame detecting circuits may limit burner turndown and change the requirements for ignition. Flame monitoring controls that stop the spark as soon as a signal is detected may prevent establishment of flame, particularly when using UV scanners. The flame monitoring control must maintain the spark for a fixed time interval that is long enough for ignition.**

DO NOT USE the following:

- Flame monitoring relays which interrupt the trial for ignition when the flame is detected.
- Flame sensors which supply a weak signal.
- Flame monitoring relays with low sensitivity.

Step 6: Main Gas Shut-Off Valve Train**Component Selection**

Eclipse can help design a main gas shut-off valve train that satisfies the customer and complies with all local safety standards and codes set by the authorities within

jurisdiction. Valve trains are available to accomplish 8:1 or 10:1 turndown, based on the customer's needs. Contact Eclipse for further information.

NOTE: Eclipse supports NFPA regulations (two gas shut-off valves as a minimum standard for main gas shut-off systems).

 **CAUTION**

- The shut-off valves must be opened slowly to provide a gradually increasing gas pressure for the main burner control. If the shut-off valves are opened too quickly, the gas pressure may surge.

Valve Train Size

Fuel pressure supplied to the ratio regulator inlet must be within the range specified in Datasheets 159-1 and 159-2. The valve train should be sized sufficiently to provide the specified pressure. A second main gas pressure regulator immediately upstream from the valve train gas inlet may be necessary to maintain inlet pressure to the burner.

 **WARNING**

Do not operate Linnox Straight ULE and Tee ULE burners with gas inlet pressure less than the minimum listed in Datasheets 159-1 and 159-2. Lower gas inlet pressure may cause the ratio regulator to remain fully open at lower inputs as the burner transitions from low to high fire. This can result in the

possible accumulation of unburned fuel in the burner which, in extreme situations, could cause a fire or an explosion.

Step 7: Process Temp Control System

Consult Eclipse

The system controls should always be designed to allow for the combustion air blower to be on with the air control valve fully open at combustion chambers above 250°F (121°C), when the burner is not being fired, to protect the burner from excessive heat.

The process temperature control system is used to control and monitor the temperature of the system. There is a wide variety of control and measuring equipment available.

For details, please contact Eclipse.

Step 8: Process Air Duct Design

Firing Arrangements

Burners can be configured to fire vertically (up or down) or horizontally (left or right). Systems can include complete duct mounted sections or side-plate assemblies for insertion into an existing duct.

Profile plates should be installed approximately 1/2" from the end of the flame shields as shown in Figure 3.7 below.

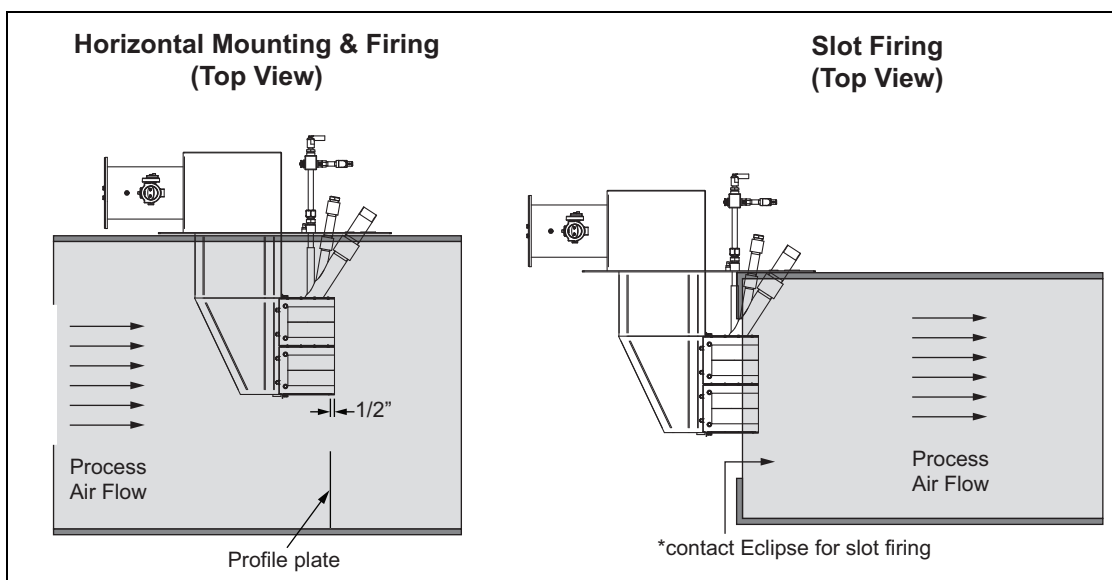

Figure 3.7.

Good Duct Design

The Linnox burner must be properly installed in the process air duct system so that the flame fires in the same direction as the process flow. There can be no cross flow of process air to the burner. The process air flow must flow uniformly past the burner. The illustration in Figure 3.10 represents good duct designs, which will best maintain the process air velocity. See appropriate datasheet for additional design details

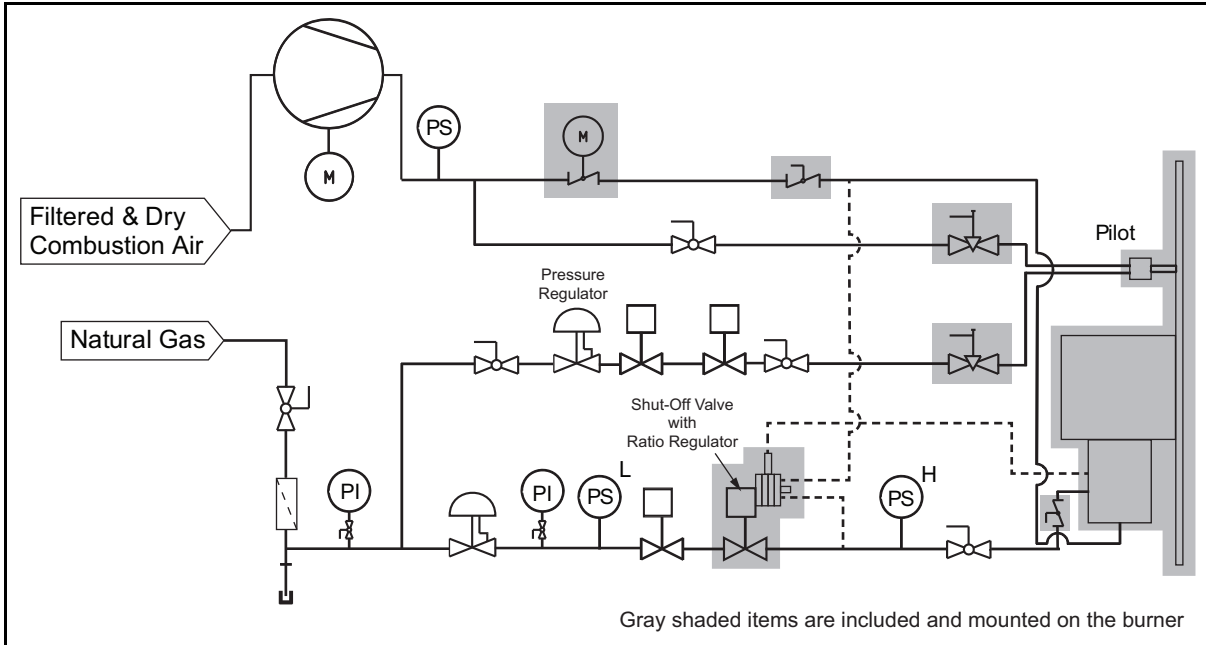

Figure 3.8. Linnox Straight ULE and Tee ULE PID 10:1 Turndown

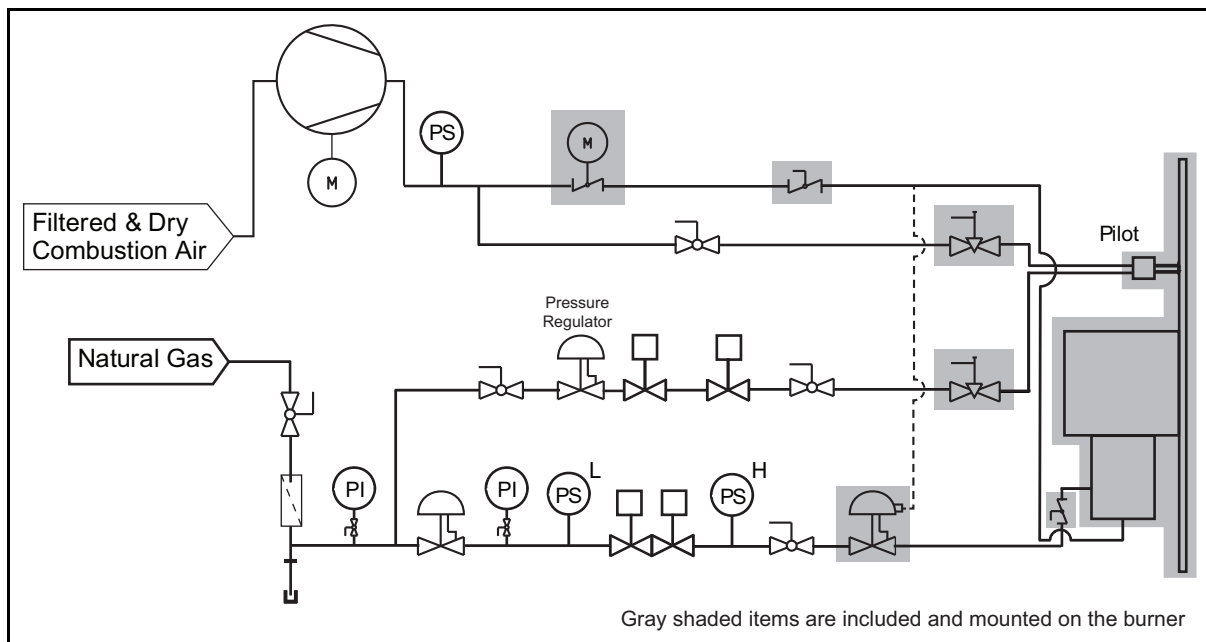

Figure 3.9. Linnox Straight ULE and Tee ULE PID 8:1 Turndown

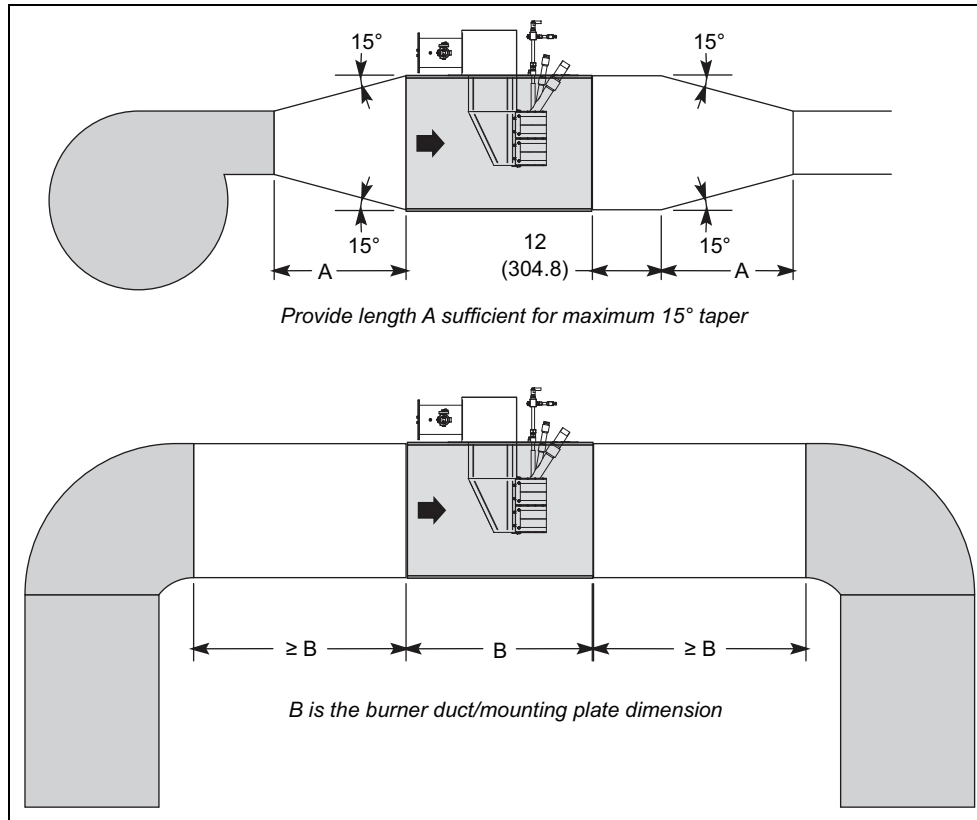

Figure 3.10. Example of Duct Design

Module Cross-Sectional Area

Burner Cross-Sectional Area

In order to size profile plates for the Linnox, the burner cross sectional area is required. The table below lists the Linnox burner cross-sectional areas per foot. Note that for

module IDs 24 through 240, the manifold width is greater than the module width. For modules 360 through 720, the module width is greater than the manifold width.

Module ID	Input per Module, kBtu/h (kW)	Burner Cross-Sectional Area per module, in ² (cm ²)
24	90 (26)	44.4 (286.5)
36	135 (40)	44.4 (286.5)
48	180 (53)	44.4 (286.5)
60	225 (66)	44.4 (286.5)
72	270 (79)	44.4 (286.5)
96	361 (105)	44.4 (286.5)
120	451 (132)	44.4 (286.5)
144	541 (158)	44.4 (286.5)
240	901 (264)	44.4 (286.5)
360	1352 (396)	55.7 (359.4)
480	1803 (527)	65.2 (420.6)
720	2704 (791)	89.3 (576.1)

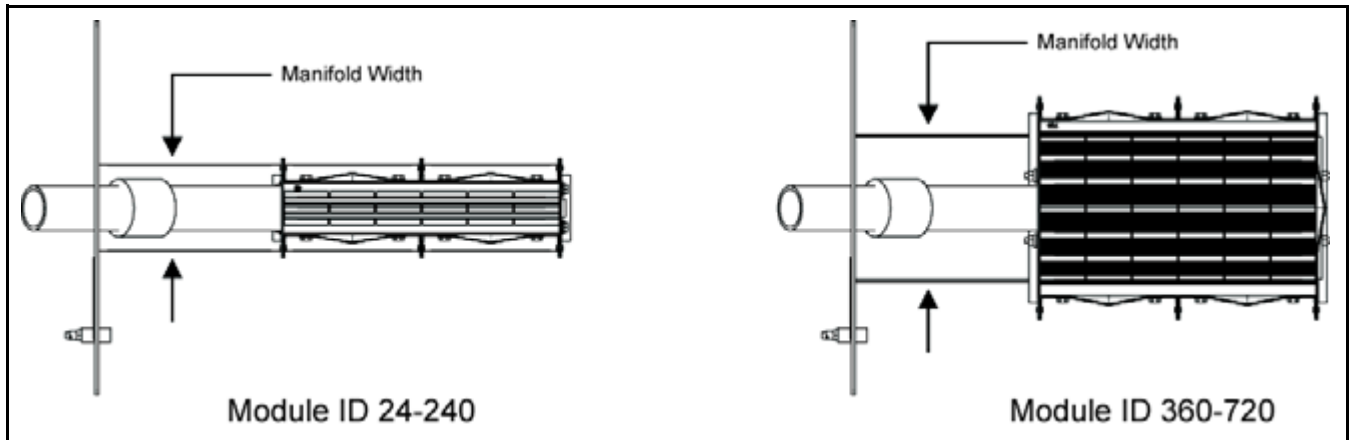

Figure 3.11.

Duct Size

The sizing of the duct is based upon the process air velocity across the burner. A velocity between 1000 and 3000 fpm (5 and 15 m/s) creates a good mixture of process air and burner flue gases.

There must also be a minimum distance of 7.9 inches (200 mm) between the burner and the duct wall to avoid excessive heat impact on the wall.

Peep sights

It is necessary that at least one peep sight be installed on the duct downstream of the burner to view the main flame and pilot flame for correct burner adjustment.

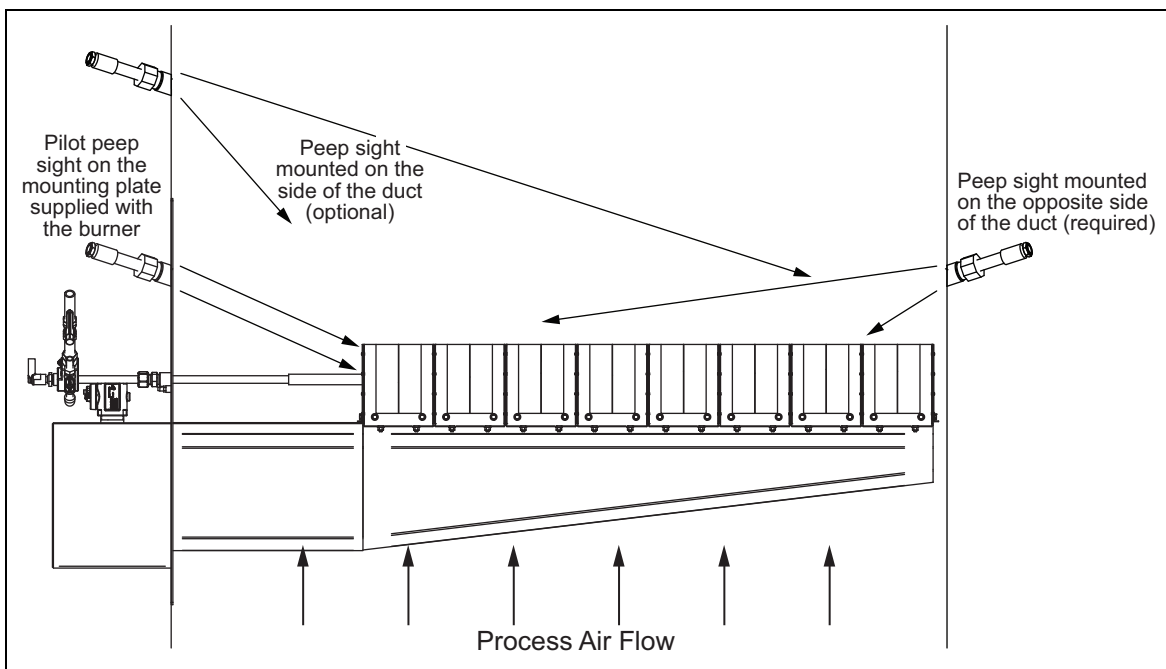

Figure 3.12.



Appendix

Conversion Factors

Metric to English

From	To	Multiply By
actual cubic meter/h (am ³ /h)	actual cubic foot/h (acfh)	35.31
normal cubic meter/h (Nm ³ /h)	standard cubic foot /h (scfh)	38.04
degrees Celsius (°C)	degrees Fahrenheit (°F)	(°C x 9/5) + 32
kilogram (kg)	pound (lb)	2.205
kilowatt (kW)	Btu/h	3415
meter (m)	foot (ft)	3.281
millibar (mbar)	inches water column ("w.c.)	0.402
millibar (mbar)	pounds/sq in (psi)	14.5 x 10 ⁻³
millimeter (mm)	inch (in)	3.94 x 10 ⁻²
MJ/Nm ³	Btu/ft ³ (standard)	26.86





Metric to Metric





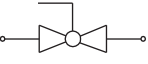
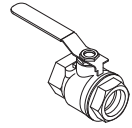
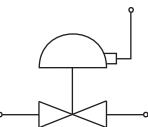
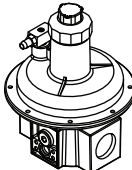
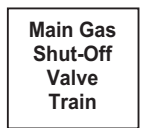

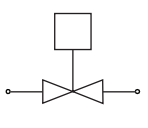
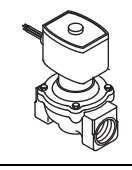

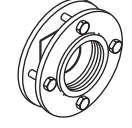
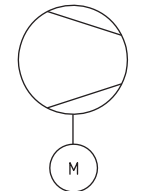
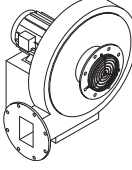

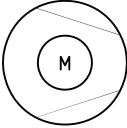
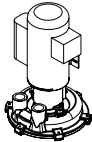
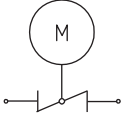
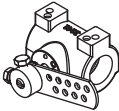
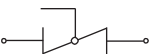
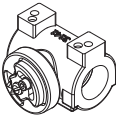
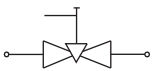

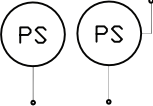
From	To	Multiply By
kiloPascals (kPa)	millibar (mbar)	10
meter (m)	millimeter (mm)	1000
millibar (mbar)	kiloPascals (kPa)	0.1
millimeter (mm)	meter (m)	0.001

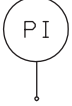
English to Metric

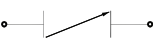
From	To	Multiply By
actual cubic foot/h (acfh)	actual cubic meter/h (am ³ /h)	2.832 x 10 ⁻²
standard cubic foot /h (scfh)	normal cubic meter/h (Nm ³ /h)	2.629 x 10 ⁻²
degrees Fahrenheit (°F)	degrees Celsius (°C)	(°F - 32) x 5/9
pound (lb)	kilogram (kg)	0.454
Btu/h	kilowatt (kW)	0.293 x 10 ⁻³
foot (ft)	meter (m)	0.3048
inches water column ("w.c.)	millibar (mbar)	2.489
pounds/sq in (psi)	millibar (mbar)	68.95
inch (in)	millimeter (mm)	25.4
Btu/ft ³ (standard)	MJ/Nm ³	37.2 x 10 ⁻³

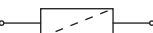
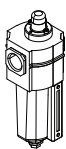
System Schematics

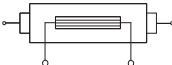
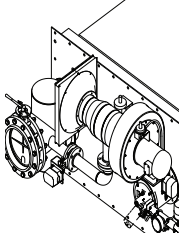
Symbol	Appearance	Name	Remarks	Bulletin/ Info Guide
		Gas Cock	Gas cocks are used to manually shut off the gas supply.	710
		Ratio Regulator	A ratio regulator is used to control the air/gas ratio. The ratio regulator is a sealed unit that adjusts the gas pressure in ratio with the air pressure. To do this, it measures the air pressure with a pressure sensing line, the impulse line. This impulse line is connected between the top of the ratio regulator and the burner body.	
		Main Gas Shut-Off Valve Train	Eclipse strongly endorses NFPA as a minimum.	790/791
		Pilot Gas Valve Train	Eclipse strongly endorses NFPA as a minimum.	790/791
		Automatic Shut-Off Valve	Shut-off valves are used to automatically shut off the gas supply on a gas system or a burner.	760
		Orifice Meter	Orifice meters are used to measure flow.	930
		Combustion Air Blower	The combustion air blower provides the combustion air to the burner(s).	610

Symbol	Appearance	Name	Remarks	Bulletin/ Info Guide
		Hermetic Booster	Booster is used to increase gas pressure.	620
		Automatic Butterfly Valve	Automatic butterfly valves are typically used to set the output of the system.	720
		Manual Butterfly Valve	Manual butterfly valves are used to balance the air or gas flow at each burner.	720
		Adjustable Limiting Orifice	Adjustable limiting orifices are used for fine adjustment of gas flow.	728/730
		Pressure Switch	A switch activated by rise or fall in pressure. A manual reset version requires pushing a button to transfer the contacts when the pressure set point is satisfied.	840
		Pressure Gauge	A device to indicate pressure.	940
		Check Valve	A check valve permits flow only in one direction and is used to prevent back flow of gas.	780
		Strainer	A strainer traps sediment to prevent blockage of sensitive components downstream.	
		Flexible Connector	Flexible connectors isolate components from vibration, mechanical, and thermal stresses.	
		Heat Exchanger	Heat exchangers transfer heat from one medium to another.	500
		Pressure Taps	Pressure taps measure static pressure.	

