

Eclipse Winnox Burners

*WX Series
Version 3*

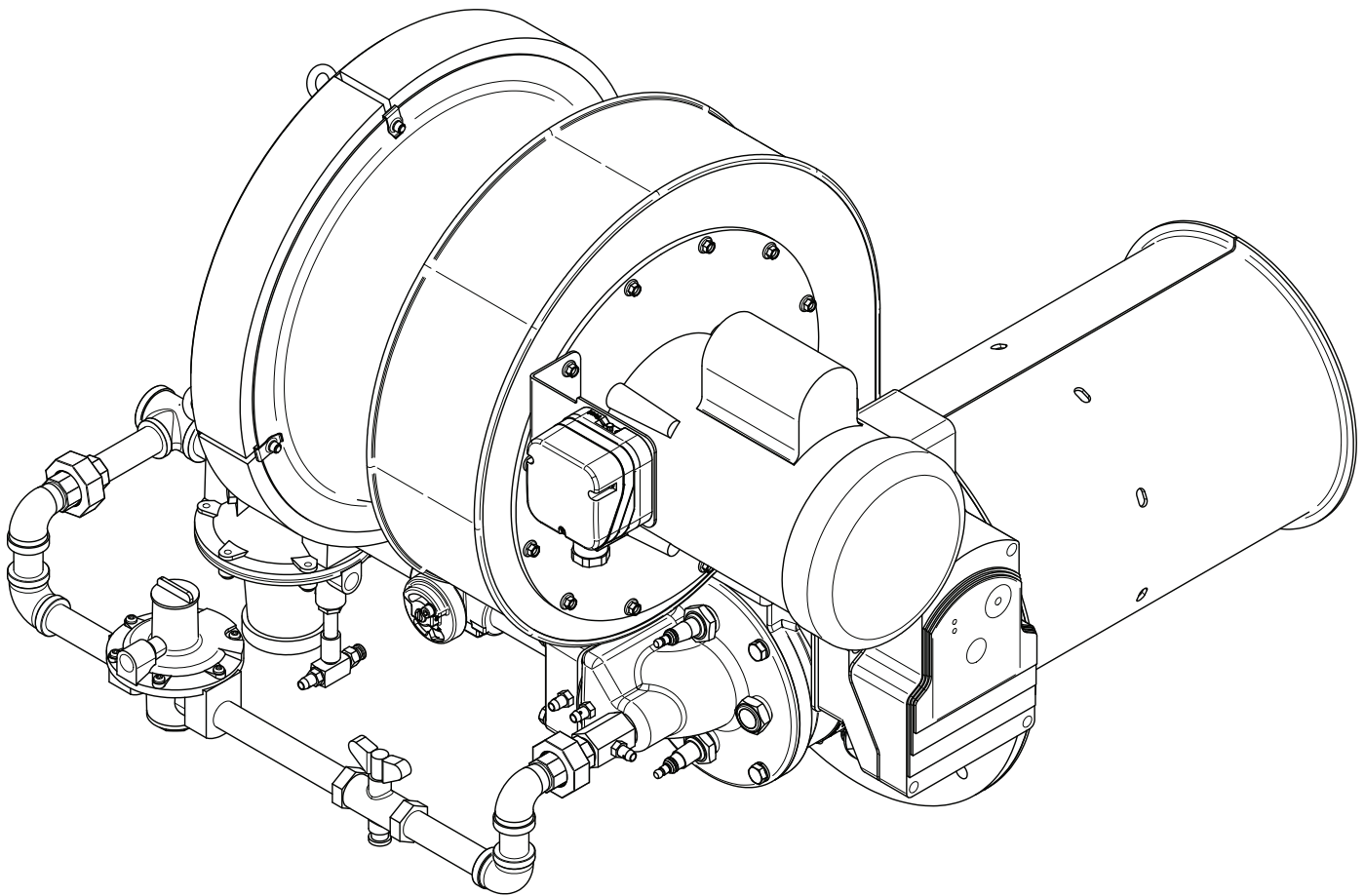

Copyright

Copyright 2007 by Honeywell International Inc. All rights reserved worldwide. This publication is protected by federal regulation and shall not be copied, distributed, transmitted, transcribed or translated into any human or computer language, in any form or by any means, to any third parties, without the express written consent of Honeywell Eclipse.

Disclaimer Notice

In accordance with the manufacturer's policy of continual product improvement, the product presented in this brochure is subject to change without notice or obligation.

The material in this manual is believed adequate for the intended use of the product. If the product is used for purposes other than those specified herein, confirmation of validity and suitability must be obtained. Honeywell Eclipse warrants that the product itself does not infringe upon any United States patents. No further warranty is expressed or implied.

Liability & Warranty

We have made every effort to make this manual as accurate and complete as possible. Should you find errors or omissions, please bring them to our attention so that we may correct them. In this way we hope to improve our product documentation for the benefit of our customers. Please send your corrections and comments to our Technical Documentation Specialist.

It must be understood that Honeywell Eclipse's liability for its product, whether due to breach of warranty, negligence, strict liability, or otherwise is limited to the furnishing of replacement parts and Honeywell Eclipse will not be liable for any other injury, loss, damage or

expenses, whether direct or consequential, including but not limited to loss of use, income, or damage to material arising in connection with the sale, installation, use of, inability to use, or the repair or replacement of Honeywell Eclipse's products.

Any operation expressly prohibited in this manual, any adjustment, or assembly procedures not recommended or authorized in these instructions shall void the warranty.

Document Conventions

There are several special symbols in this document. You must know their meaning and importance.

The explanation of these symbols follows below. Please read it thoroughly.

How To Get Help

If you need help, contact your local Honeywell Eclipse representative. You can also contact Honeywell Eclipse at:

1665 Elmwood Rd.
Rockford, Illinois 61103 U.S.A.
Phone: 815-877-3031
Fax: 815-877-3336

Please have the information on the product label available when contacting the factory so we may better serve you.

 ECLIPSE <small>Innovative Thermal Solutions</small>	www.eclipsenet.com
Product Name	
Item #	
S/N	
DD MMM YYYY	



This is the safety alert symbol. It is used to alert you to potential personal injury hazards. Obey all safety messages that follow this symbol to avoid possible injury or death.



Indicates a hazardous situation which, if not avoided, will result in death or serious injury.



Indicates a hazardous situation which, if not avoided, could result in death or serious injury.



Indicates a hazardous situation which, if not avoided, could result in minor or moderate injury.

NOTICE

Is used to address practices not related to personal injury.

NOTE

Indicates an important part of text. Read thoroughly.

Table of Contents

Introduction	4
Product Description	4
Audience.....	4
Winnox Documents	4
Safety	5
Safety Warnings	5
Capabilities	5
Operator Training	5
Replacement Parts	5
Installation	6
Introduction.....	6
Handling & Storage	6
Approvals of Components	6
Checklist Before Installation	7
Installing the Flame Sensor	7
Burner Mounting	7
Gas Piping	9
Checklist After Installation	10
Remote Blower Air Pre-Mix Line Installation (WX0850 only)	10
Adjustment, Start & Stop	11
Step 1: Reset the system	11
Step 2: Set low fire air	12
Step 3: Ignite the burner	13
Step 4: Set low fire gas.....	14
Step 5: Set high fire gas	15
Step 6: Verify Settings	15
Maintenance & Troubleshooting	17
Monthly Checklist	17
Yearly Checklist.....	17
Recommended Spare Parts	18
Troubleshooting.....	18
Appendix	i
System Schematics	ii
Notes	iv

Introduction

1

Product Description

The Winnox is a nozzle-mix type, low-emissions burner designed for direct and indirect air heating, and oven applications up to 1800°F (980°C).

The burner package includes a combustion air blower and ratio regulator to fire over a wide gas turndown range at a controlled ratio.

The burner is designed for:

- low NO_x and CO emissions
- efficient ratio controlled combustion
- reliable burner operation
- simple burner adjustment
- direct spark ignition
- multiple fuel capability

The wide variety of options and configurations are available due to the modular design of the burner.

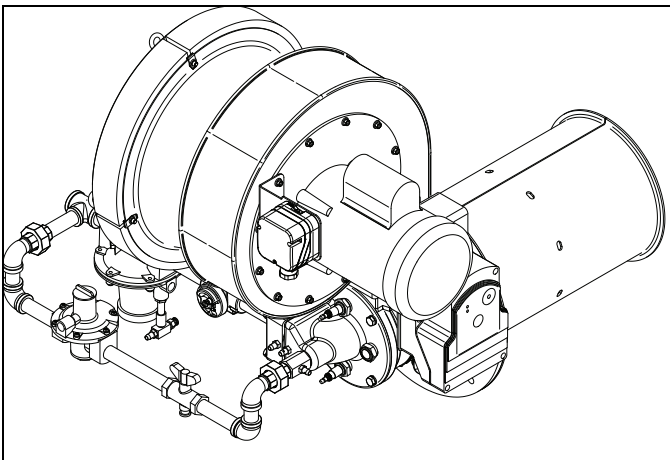

Figure 1.1 Winnox Burner

Audience

This manual has been written for people who are already familiar with all aspects of a nozzle-mix burner and its add-on components, also referred to as “the burner system”.

These aspects are:

- Design / Selection
- Use
- Maintenance

The audience is expected to have previous experience with this type of equipment.

Winnox Documents

Installation Guide No. 111

- This document

Datasheet, Series 111

- Available for individual WX models
- Required to complete design and selection

Design Guide No. 111

- Used with Datasheet to design burner system

Spare Parts List, Series 111

- Recommended replacement part information

Related Documents

- EFE 825 (Combustion Engineering Guide)
- Eclipse Bulletins and Info Guides: 710, 732, 756, 760, 930

Important notices which help provide safe burner operation will be found in this section. To avoid personal injury and damage to the property or facility, the following warnings must be observed. All involved personnel should read this entire manual carefully before attempting to start or operate this system. If any part of the information in this manual is not understood, contact Eclipse before continuing.

Safety Warnings



DANGER

- **The burners, described herein, are designed to mix fuel with air and burn the resulting mixture. All fuel burning devices are capable of producing fires and explosions if improperly applied, installed, adjusted, controlled or maintained.**
- **Do not bypass any safety feature; fire or explosion could result.**
- **Never try to light a burner if it shows signs of damage or malfunction.**



WARNING

- **The burner and duct sections are likely to have HOT surfaces. Always wear the appropriate protective equipment when approaching the burner.**
- **Eclipse products are designed to minimize the use of materials that contain crystalline silica. Examples of these chemicals are: respirable crystalline silica from bricks, cement or other masonry products and respirable refractory ceramic fibers from insulating blankets, boards, or gaskets. Despite these efforts, dust created by sanding, sawing, grinding, cutting and other construction activities could release crystalline silica. Crystalline silica is known to cause cancer, and health risks from the exposure to these chemicals vary depending on the frequency and length of exposure to these chemicals. To reduce the risk, limit exposure to these chemicals, work in a well-ventilated area and wear approved personal protective safety equipment for these chemicals.**

NOTICE

- **This manual provides information regarding the use of these burners for their specific design purpose. Do not deviate from any instructions or application limits described herein without written approval from Eclipse.**

Capabilities

Only qualified personnel, with sufficient mechanical aptitude and experience with combustion equipment, should adjust, maintain or troubleshoot any mechanical or electrical part of this system. Contact Eclipse for any needed commissioning assistance.

Operator Training

The best safety precaution is an alert and trained operator. Train new operators thoroughly and have them demonstrate an adequate understanding of the equipment and its operation. A regular retraining schedule should be administered to ensure operators maintain a high degree of proficiency. Contact Eclipse for any needed site-specific training.

Replacement Parts

Order replacement parts from Eclipse only. All Eclipse approved valves or switches should carry UL, FM, CSA, CGA and/or CE approval where applicable.

Installation

3

Introduction

In this chapter you will find information and instructions needed to install the burner and system components.

Handling & Storage

Handling

- Make sure that the area is clean.
- Protect the components from the weather, damage, dirt and moisture.
- Protect the components from excessive temperatures and humidity.
- Take care not to drop or damage components.

Storage

- Make sure that the components are clean and free of damage.
- Store the components in a cool, clean, dry room.
- After you have made sure that everything is present and in good condition, keep the components in the original package as long as possible.

Approval of Components

Limit Controls & Safety Equipment

All limit controls and safety equipment must comply with all applicable local codes and/or standards and must be listed for combustion safety by an independent testing agency. Typical application examples include:

- American: NFPA 86 with listing marks from UL, FM, CSA
- European: EN 746-2 with CE mark from TuV, Gastec, Advantica

Electrical Wiring

All the electrical wiring must comply with all applicable local codes and/or standards such as:

- NFPA Standard 70
- IEC60364
- CSA C22
- BS7671

Gas Piping

All the gas piping must comply with all applicable local codes and/or standards such as:

- NFPA Standard 54
- ANSI Z223
- EN 746-2

Where to Get the Standards:

The NFPA Standards are available from:

National Fire Protection Agency
Batterymarch Park
Quincy, MA 02269
www.nfpa.org

The ANSI Standards are available from:

American National Standard Institute
1430 Broadway
New York, NY 10018
www.ansi.org

The UL Standards are available from:

333 Pfingsten Road
Northbrook, IL 60062
www.ul.com

The FM Standards are available from:

1151 Boston-Providence Turnpike
PO Box 9102
Norwood, MA 02062
www.fmglobal.com/approvals

Information on the EN standards and where to get them is available from:

Comité Européen de Normalisation
Stassartstraat 36
B-1050 Brussels
Phone: +32-25196811
Fax: +32-25196819
www.cen.eu

Comité Européen de Normalisation Electronique
Stassartstraat 36
B-1050 Brussels
Phone: +32-25196871
Fax: +32-25196919
www.cenelec.org

Checklist Before Installation

Intake

To admit fresh combustion air from outdoors, provide an opening in the room of at least one square inch per 4,000 BTU/hr (1.17 kW). If there are corrosive fumes or materials in the air, then supply the burner with clean air from an uncontaminated area, or provide a sufficient air filtering system.

Exhaust

Do not allow exhaust fumes to accumulate in the work area. Provide some positive means for exhausting from the furnace and the building.

Access

Make sure that you install the burner in such a way that you can gain easy access for inspection and maintenance.

Environment

Make sure the local environment matches the original operating specifications. Check the following items:

- Voltage, frequency and stability of the electrical power
- Type and supply pressure of the fuel
- Availability of enough fresh, clean combustion air
- Humidity, altitude and temperature of air
- Presence of damaging corrosive gases in the air
- Prevent direct exposure to water

Installing the Flame Sensor

1. Install the flame sensor into the 1/2" NPT opening in the rear cover.
2. Make sure that you connect the flame sensor of a burner to the electrical circuit of that burner.



DANGER

- **Connecting the flame sensor of a burner to the electrical circuit of the wrong burner can result in a fire or explosion.**

There are two different types of flame sensors; UV scanner and flame rod.

UV Scanner

The UV scanner must be compatible to the flame monitoring control that is used. Refer to the manual of your selected control for proper selection of the scanner.

Flame Rod

NOTE: Only specific burner sizes with alloy or silicon carbide combustors can use a flame rod (see specific burner datasheets).

For detailed information on how to install and connect a flamerod, refer to Info Guide 832.

Installing the Spark Plug

Install the spark plug into the opening in the rear cover.

NOTE: Do *not* apply any grease to the threads of the spark plug or bad grounding of the spark plug may occur, resulting in a weak spark.

NOTICE

- **If flame monitoring controls other than those recommended in the Design Guide are used contact Eclipse to determine how the burner performance may be affected, adjustments may vary from Eclipse published values. Consult with the engineer who specified the alternate control for limitations.**

Burner Mounting

Chamber Opening

Provide an opening in the chamber wall at least 1/2" (12 mm) larger in diameter than the outside diameter of the combustor (1/4" - 6 mm per side). The combustor diameter can be found in the Winnox datasheet, series 111.

Provide an accessible pressure tap on the chamber wall to measure the pressure inside the firing chamber. The pressure tap should be located near the burner.

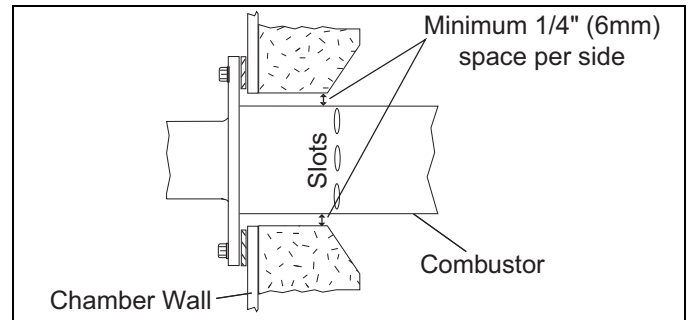

Figure 3.1. Chamber Opening

Mounting Pattern

Attach eight mounting bolts to the chamber wall. Position these bolts to match the clearance holes (C) on the burner mounting flange. Refer to Winnox datasheet, series 111.

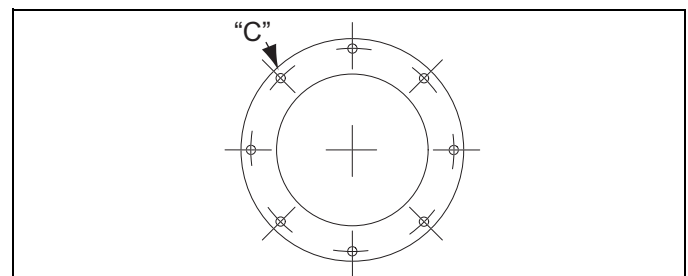

Figure 3.2. Mounting Pattern

Tube Shrouding Considerations

Applications in which there is process air flow perpendicular to and across the Winnox combustor greater than 1000 ft/min (5 m/s) may cause flame instability and/or high production of CO emissions. In these applications a shroud may be required to shield the combustor. Contact Eclipse for more information.

Chamber Wall

Make sure the chamber wall ② is strong enough to support the weight of the burner ③. If necessary, reinforce the mounting area. See Figure 3.3.

NOTE: The slots in the combustor must not be covered with insulation. If necessary, taper the chamber insulation at a minimum of 45° to provide clearance for the combustor slots. Slot dimensions can be found in the Winnox datasheet, series 111.

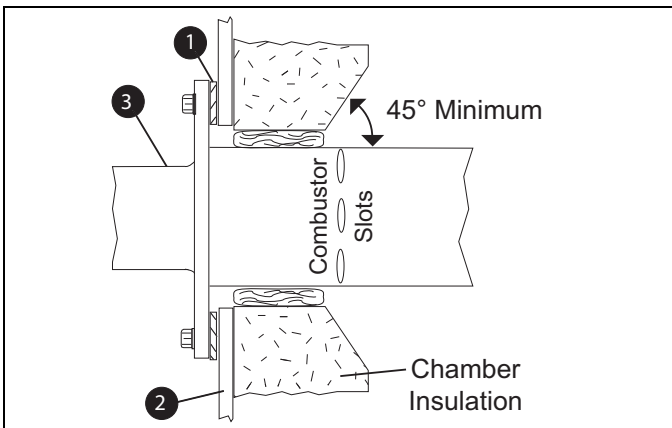

Figure 3.3. Chamber Wall

Burner Mounting

Mount the burner to the chamber wall using eight (8) customer supplied nuts and lock washers.

Alloy Combustion Tube

1. Be sure gasket ① is installed between burner ③ and chamber wall ②. See Figure 3.4.
2. Pack fiber insulation around the tube to a depth not beyond the combustor slot position, as shown in Figure 3.4.



CAUTION

- Placing insulation over combustor slots will impede burner performance and decrease combustor life.

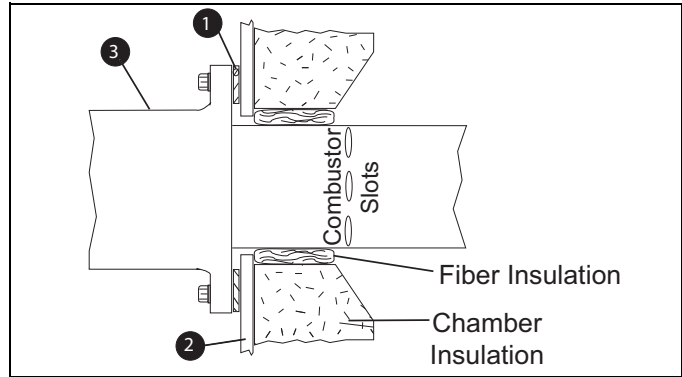

Figure 3.4. Alloy Combustion Tube

Refractory Plug

When using the refractory plug the customer must provide a refractory combustion tube. The customer is responsible for supplying all refractory materials for combustion tube field installation as follows:

1. Install the chosen refractory realizing it is essential that:
 - The combustion tube dimensions are held as given in the Winnox Datasheet series 111. See Figure 3.5.
 - The inside diameter of the combustion tube is concentric with the refractory plug.
2. Support refractory combustion tube according to the refractory supplier's recommendations. The alloy anchors should be coated with bitumastic whenever they are used.
3. Fiber insulation must be installed between the refractory plug and customer supplied refractory combustion tube.
4. After the burner and refractory have been installed, a proper curing schedule should be followed according to refractory supplier's recommendations.

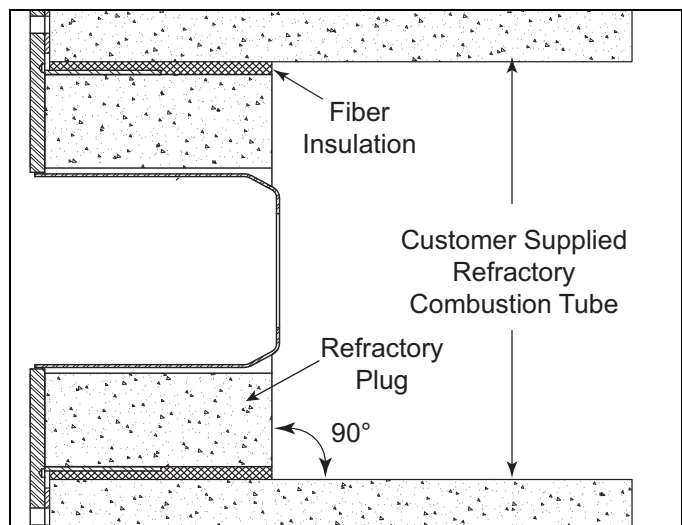

Figure 3.5. Refractory Plug

Gas Piping

Burner Piping

The burner is factory assembled and shipped as ordered.

NOTE: If it is necessary to redirect piping, remove the **outer four bolts only ①**. Rotate the rear cover and replace bolts. When reassembling, be sure that:

- ratio regulator spring column ② is pointing down
- the bypass regulator spring column is pointing up
- arrow on the ratio regulator points in the direction of gas flow
- integral fuel orifice and o-rings ③ are reinstalled
- the same straight run of pipe ④ remains between the ratio regulator and the burner.

! CAUTION

- Do not attempt to redirect piping by removing the inner circle bolts ⑤. Internal burner parts will be damaged.

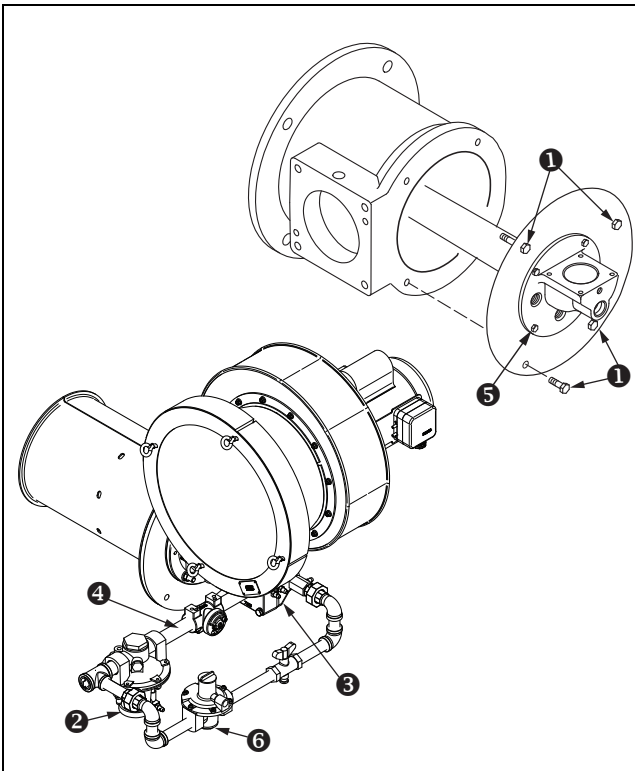

Figure 3.6. Burner Piping

! CAUTION

- Do not alter the bypass regulator. The NFPA requires that the bypass regulator ⑥ be appropriately vented and protected.
- For applications in which the Winnox is operating indoors, a vent limiting device is installed in the bypass regulator.
- For applications in which the Winnox is operating outdoors, an insect/rain protector is installed in the bypass regulator.

Supply Piping

Inlet pressure to the ratio regulator must stay within specified limits. Refer to the appropriate Winnox datasheet, series 111.

- Locate the valve train close to the burner. The gas must reach the burner during the fixed trial for ignition period.
- Sufficiently size the shut off valve in the valve train.
- Make sure piping is large enough to accommodate flow required to meet burner input.
- Minimize piping elbows.
- Install fuel flow measurement device ① upstream from the burner inlet.
- If necessary to maintain inlet pressures to the burner (see datasheet for your burner), install a gas pressure regulator ② upstream of the burner inlet and downstream of the valve train and fuel measurement device ①.

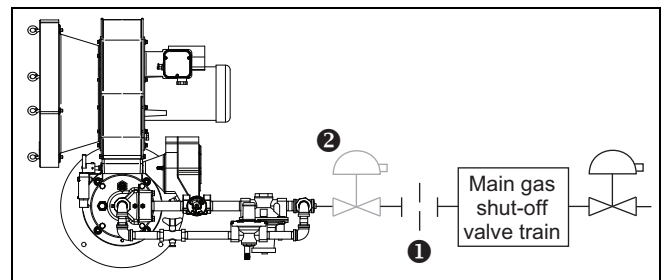

Figure 3.7. Supply Piping

Pipe Connections

Installation of a pipe union in the gas line is recommended to simplify burner removal.

Use of flexible pipe is optional.

NOTE: Flexible pipe causes higher pressure drops than standard pipe. Consider this when sizing your gas lines.

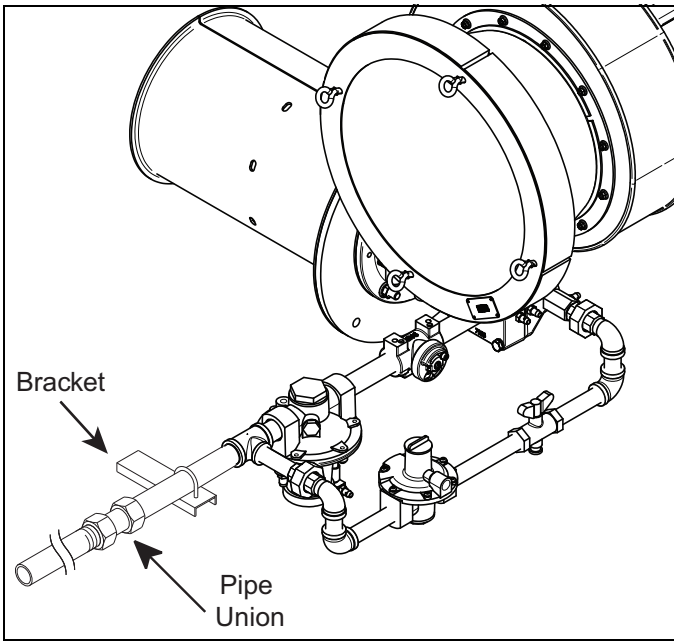

Figure 3.8. Pipe Connections

Piping Support

Use brackets or hangers to support the gas piping. If you have questions, consult your local gas company.

Control Motor

Install a control motor to modulate the air butterfly valve if not factory installed on the burner.

NOTE: Be sure the control motor shaft and air butterfly valve shaft are aligned properly.

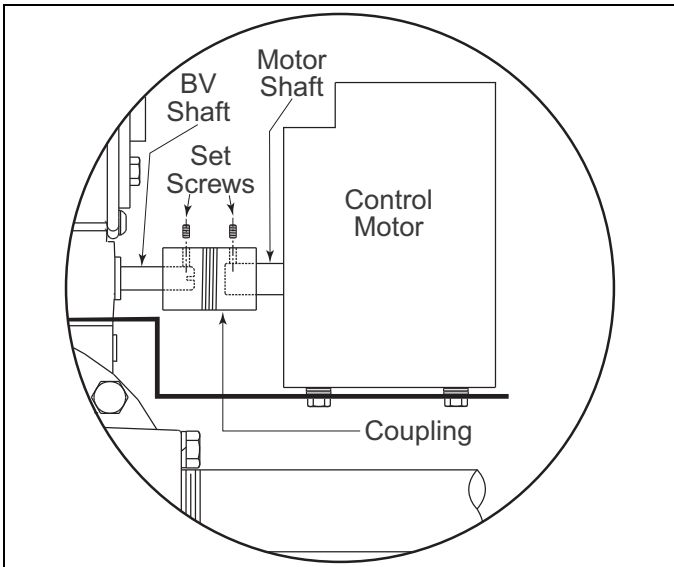

Figure 3.9. Control Motor

Checklist After Installation

To verify the system was properly installed, perform the following checks:

1. Be sure there are no leaks in the gas lines.
2. Be sure all the components contained in the flame monitoring and control systems are properly installed. This includes verifying that:
 - all the switches are installed in the correct locations.
 - all wiring, pressure, and impulse lines are properly connected.
3. Be sure all components of the spark ignition system are installed and functioning properly.
4. Be sure the blower rotates in the proper direction. If the rotation is incorrect, have a qualified electrician rewire the blower to rotate in the proper direction.
5. Be sure all valves are installed in the proper location and correctly oriented relative to the flow direction.

Remote Blower Air Pre-Mix Line Installation (WX0850 only)

When using a remote blower instead of the packaged blower on the WX0850, the low fire air pre-mix line must be installed to the combustion air line. 1/4" diameter braided hose is recommended, located as shown in figure 3.10.

NOTE: A 24" length of 1/4" diameter braided hose is included with the burner.

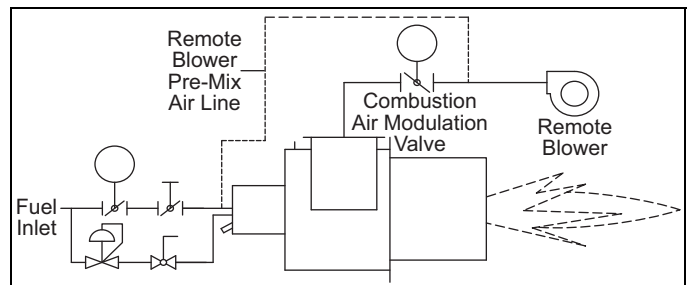

Figure 3.10.

Adjustment, Start & Stop

4

In this chapter, you will find instructions on how to adjust, start, and stop the burner system. Become familiar with burner control methods before attempting to make adjustments.

DANGER

- **The Winnox burners are designed to mix fuel with air and burn the resulting mixture. All fuel burning devices are capable of producing fires and explosions if improperly applied, installed, adjusted, controlled, or maintained.**
- **Do not bypass any safety feature; fire or explosion could result.**
- **Never try to light a burner if it shows signs of damage or malfunction.**

Step 1: Reset the System

1. Set the low gas pressure switch to 20% below the “Fuel Inlet Pressure” range as specified in the appropriate datasheet.
2. Set the high gas pressure switch to 20% above the “Main Gas Inlet Pressure” range as specified in the appropriate datasheet.
3. Close all the burner gas valves – manual and automatic.
4. Try to ignite the burner; be sure the flame monitoring system indicates a flame failure.
5. Activate the pressure switches and other limit interlocks. Be sure the switches fail as intended in the event of a power failure.

DANGER

- **If simulated limits or simulated flame failure do not shut down the fuel system within the required failure response time, immediately correct the problem before proceeding. Refer to the “Troubleshooting” chart in section 5.**
6. If the burner is firing into a duct or chamber with a circulating fan, start the fan to produce full process air flow past the burner.
 7. Adjust main gas inlet pressure to the ratio regulator within the range specified in the appropriate datasheet.

WARNING

- **Gas inlet pressures must stay within the specified range. Pressure above the specified range can damage the ratio regulator.**
 - **Pressure below the specified range can impair the ability of the ratio regulator to control the gas flow.**
 - **Operating the system outside the specified range can cause excess fuel consumption and the possible accumulation of unburned fuel in the chamber.**
 - **In extreme cases, this accumulation of unburned fuel may cause fires or explosions.**
8. Verify the actuator opens the air butterfly valve towards the back of the burner as shown in Figure 4.1. If it doesn't, refer to the actuator's literature for instructions on how to reverse the direction.

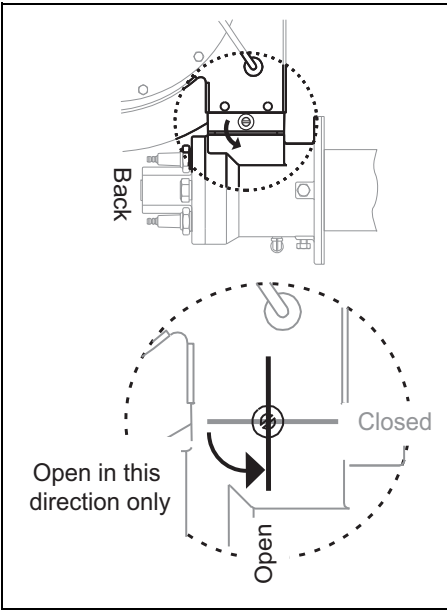

Figure 4.1. Air Butterfly Valve Open Direction

Step 2: Set Low Fire Air

1. Start combustion air blower.
2. Drive control motor to low fire position.
3. Measure the air differential pressure between **Tap C** and the combustion chamber.

NOTE: The pressure tap is in the open position when the screw inside the tap is unscrewed approximately 1/2 turn. Do not remove the screw. Be sure to tighten the pressure tap screw clockwise to the closed position after pressure measurements have been taken.

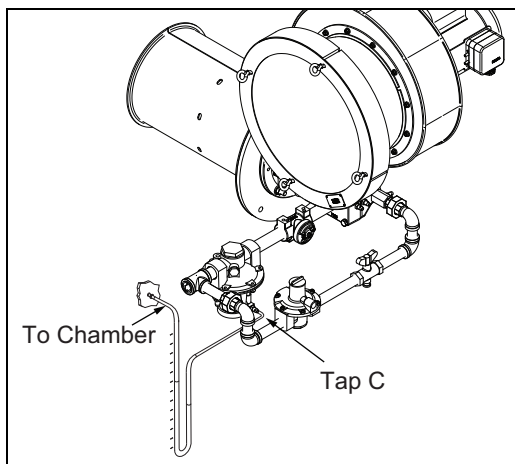

Figure 4.2. Air Differential Pressure

4. Set low fire air.
 - a. Loosen the set screw ❶ on the burner side of coupling.
There is a slot in the end of the butterfly valve shaft that is parallel to the air damper. This slot is used for visual indication of the butterfly valve position. The butterfly valve is closed when the shaft slot is perpendicular to the direction of air flow through the butterfly valve.
 - b. Rotate the air butterfly valve shaft to a fully closed position. (Holes in the butterfly valve will supply low fire air.)
 - c. When firing into a positive chamber pressure, rotate the air butterfly valve from the closed position in the direction of actuator travel to obtain a minimum 0.3" w.c. (0,8 mbar) air differential pressure.
 - d. Hold the butterfly valve shaft firmly in place and tighten set screw ❶.

High fire air adjustment is not required if the burner is firing into a neutral pressure chamber and a 90° travel control motor is used. It may be necessary to limit control motor stroke to less than 90° if firing into a large negative chamber. Contact Eclipse for further information.

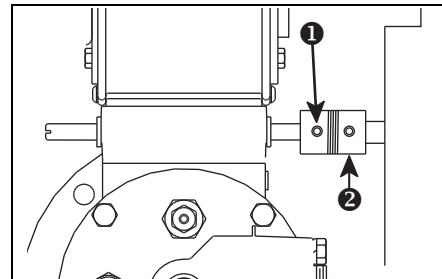

Figure 4.3. Air Butterfly Valve Adjustment

5. Verify high fire air:
 - a. Drive control motor to high fire, full open.
 - b. Compare the high fire air differential pressure between **Tap C** and the combustion chamber to the approximate datasheet chart "Air Δp vs. Input". If high fire air is insufficient, refer to section 5, "Troubleshooting & Maintenance", in this document.
6. Return the control motor to the low fire position.
7. Close the pressure taps.

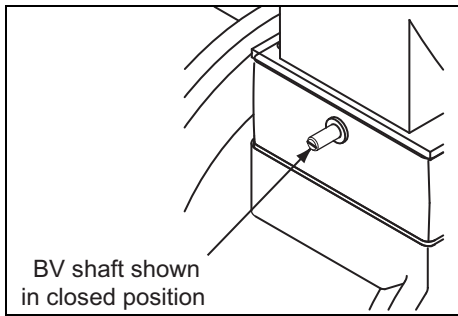

Figure 4.4. Air Butterfly Valve Shaft

Step 3: Ignite the Burner

Low Fire Start



- These procedures are written with the assumption the burner has a flame monitoring control system installed and operating. A proper purge cycle must be part of the system and purge timing should not be bypassed.

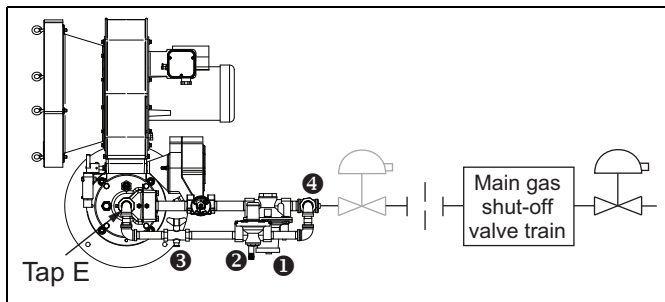

Figure 4.5. Low Fire Start

- Drive control motor to low fire.
- Be sure combustion air blower is running.
- Open main gas manual shut off valves.
- With pressure taps open, connect the manometer between **Tap E** and the chamber.
- Set system control to stay at low fire during and after ignition sequence.
- Attempt to ignite burner.
- During trial for ignition, adjust bypass pressure regulator **2** and adjustable limiting orifice **3** to achieve the appropriate Δp between **Tap E** and the chamber as listed in the appropriate datasheet.

NOTE: If viewing the flame, it should be blue with flashes of yellow. The flame should be completely within the combustion tube. When firing propane or butane, a proper low fire flame may have sustained flashes of yellow.

- If burner does not ignite.
 - Shut off gas.
 - When chamber temperature is below 250°F (121°C), shut off combustion air blower.
 - Restart combustion air blower, drive through purge cycle and ignite the burner.
 - Measure low fire gas pressure to the burner gas inlet **4**. Verify pressure at **4** is within the range specified on the datasheet for your burner. range specified on the datasheet for your burner.

10. After ignition, verify low fire flame:

- Shut off gas.
- When chamber temperature is below 250°F (121°C), shut off combustion air blower.
- Restart combustion air blower and ignite burner.
- Measure low fire gas pressure to the burner gas inlet **4**. Verify pressure at **4** is within the range specified on the datasheet for your burner.
- Verify repeatability of ignition and low fire flame signal.

NOTE: If the flame signal is too low, use the bypass regulator **2** and/or the adjustable limiting orifice **3** to increase the pressure at Tap E and provide better flame signal. However, this can have a negative impact on emissions and/or nozzle life.

11. Close all pressure taps.

Pilot Start Option



- These procedures are written with the assumption the burner has a flame monitoring control system installed and operating. A proper purge cycle must be part of the system and purge timing should not be bypassed.

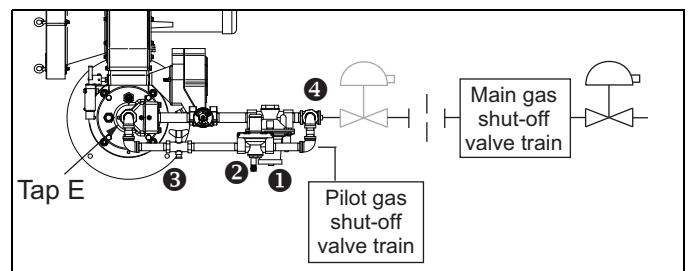

Figure 4.6. Low Fire Start with Pilot Start Option

- Drive control motor to low fire.
- Be sure combustion air blower is running.
- Open pilot gas manual shut off valve.

NOTE: Be sure main gas manual shut off valves are closed.

4. With pressure taps open, connect a manometer between **Tap E** and the chamber.
5. Set system control to stay at low fire during and after ignition sequence.
6. Attempt to ignite burner.
7. During trial for ignition, adjust bypass pressure regulator ② and adjustable limiting orifice ③ to achieve the appropriate Δp between **Tap E** and the chamber as listed in the appropriate datasheet.

NOTE: If viewing the flame, it should be blue with flashes of yellow. The flame should be completely within the combustion tube. When firing propane or butane, a proper low fire flame may have sustained flashes of yellow.

8. If burner does not ignite:
 - a. Attempt to ignite the burner again to purge air from the gas piping.
 - b. If burner still does not ignite, adjust bypass pressure regulator ② a half turn clockwise to increase gas flow.
 - c. Repeat until burner ignites. If necessary, refer to Chapter 5, "Maintenance & Troubleshooting" in this manual.
10. After ignition, verify bypass flame:
 - a. Shut off gas. When chamber temperature is below 250°F (121°C), shut off combustion air blower.
 - b. Restart combustion air blower, drive through purge cycle, and ignite burner.
 - c. Measure low fire gas pressure to the burner gas inlet ④. Verify pressure at ④ is within the range specified on the datasheet for your burner.
 - d. Verify repeatability of ignition and low fire flame signal.
11. Close all pressure taps.

Step 4: Set Low Fire Gas



WARNING

■ This procedure is written with the assumption the burner has a flame monitoring control system installed and operating. A proper purge cycle must be part of the system and purge timing should not be bypassed.

1. Set manual gas butterfly valve to 75% open. See Figure 4.8.

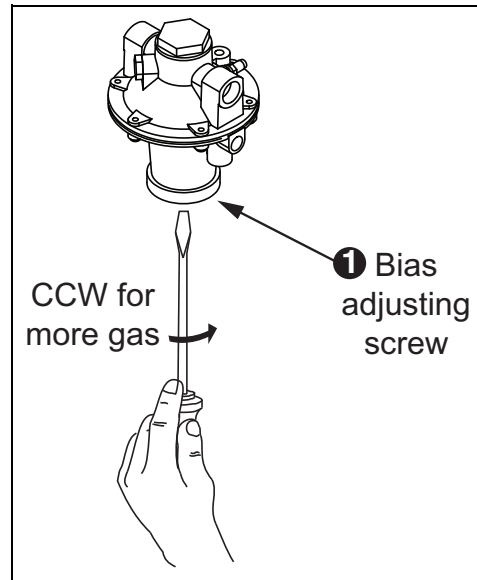

Figure 4.7. Ratio Regulator Adjustment

NOTE: To adjust manual butterfly valve:

- a. Loosen set screw
- b. Turn dial
- c. Tighten set screw

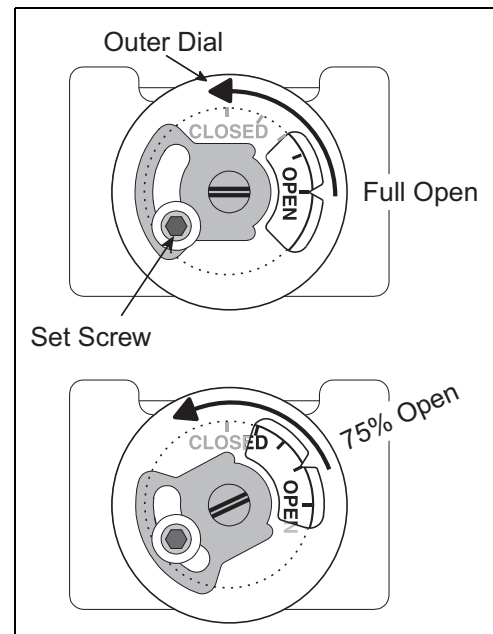

Figure 4.8. Manual Butterfly Valve Adjustment

3. Open all manual gas shut off valves.
4. Set system control to stay at low fire during and after ignition sequence.
5. With taps open, connect manometer between **Tap B** and the combustion chamber.
6. Ignite the burner.

NOTE: If viewing the flame, it should be blue with flashes of yellow. The flame should be completely within the combustion tube. When firing propane or butane, a proper low fire flame may have sustained flashes of yellow.

7. Verify low fire flame.
 - a. Drive control motor from low fire and back. Verify low fire and stable flame signal are repeat-ed.
 - b. Turn the burner off and repeat the ignition sequence. Verify low fire and stable flame signal are repeated.
8. Close all pressure taps.

Step 5: Set High Fire Gas

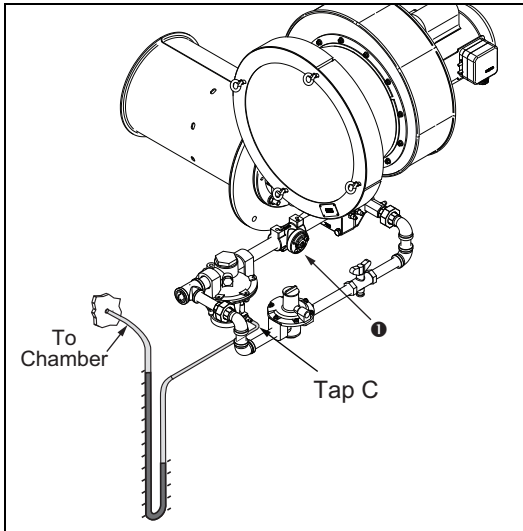

Figure 4.9. High Fire Gas Adjustment

1. Set manual gas butterfly valve to 75% open. See Figure 4.8.

NOTE: To adjust manual butterfly valve:

- a. Loosen set screw
 - b. Turn dial
 - c. Tighten set screw
2. With burner lit, drive control motor to high fire position.
 3. Measure air loading line pressure from **Tap C** to the chamber.
 4. Refer to the “Air ΔP vs. Input” graph on page 2 of the appropriate Eclipse Data Sheet. Find your measured high fire air ΔP “w.c. (mbar) on vertical axis at left and plot the intersection point it makes with performance curve in center of chart. Follow chart straight down from this intersection point to confirm the desired high fire burner input Btu/h (kW) charted on horizontal axis across the bottom.
 5. Calculate the required gas flow scfh (Nm³/h) for the desired high fire burner input Btu/h (kW).

Example: (500,000 Btu/h input) x (1 cuft Natural Gas/1000 Btu) = 500 cuft/h or scfh of Natural Gas.

6. Measure existing gas ΔP “w.c. (mbar) across customer supplied in-line fuel orifice meter, and using the manufacturer’s conversion flow chart for the fuel orifice meter, calculate* the existing gas flow scfh (Nm³/h) through orifice.
- (* = making the manufacturer’s prescribed corrections for Fuel Type, Temperature, and Elevation.)

7. If the required gas flow scfh (Nm³/h) from step 5 does not correspond with the existing gas flow scfh (Nm³/h) from step 6, adjust existing gas flow using manual butterfly valve (refer to step 1 for adjustment procedure) to match required gas flow for the desired high fire burner input.
8. If required gas flow cannot be achieved, refer to Chapter 5, “Maintenance and Troubleshooting”.

Step 6: Verify Settings

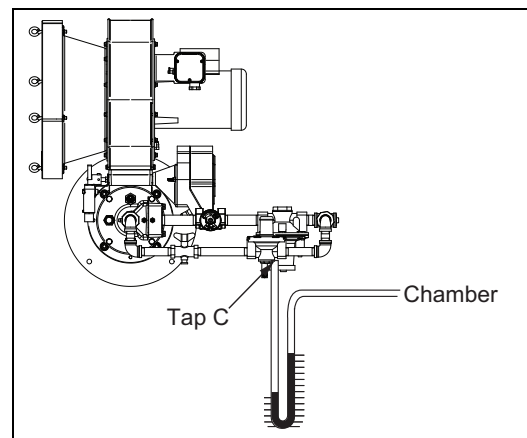

Figure 4.10. Verify Pressure Settings

1. With burner lit, drive control motor to high fire.
2. Wait for the chamber to reach normal operating conditions (e.g. chamber temperature, process flows, etc.).
3. Measure high fire fuel using fuel flow measurement device. Compare this to the rated high fire on datasheet.
4. Measure high fire air differential pressure between **Tap C** and the chamber. Compare this pressure to the “Air Δp vs. Input” chart on the datasheet.
5. Drive the control motor to low fire and verify low fire flame signal and flame appearance (if viewing).
6. Cycle burner from high to low several times to check repeatability of settings.

7. Readjust burner if the settings do not repeat as expected. If necessary, refer to Chapter 5, "Maintenance & Troubleshooting".
8. Use the Systems Schematics on Appendix page ii to record all setup data as an aid for future troubleshooting and setup operations.



CAUTION

- **Do not turn the combustion air blower off until the chamber temperature is below 250°F (121°C). This will prevent hot gases from back flowing into the burner and blower causing damage to the burner.**
9. Stop the burner.

Maintenance & Troubleshooting

5

This section is divided into two parts. The first part describes the maintenance procedures, and the second part helps you to identify problems that may occur and gives recommendations on how to solve these problems.

Preventative maintenance is the key to a reliable, safe and efficient system. The following are suggested guidelines for periodic maintenance. Burners in severe environments or operational conditions should be checked more frequently.

NOTE: The monthly and yearly lists are an average interval. If your environment is dirty, then the intervals may be shorter. Check with local authorities having jurisdiction on their recommended maintenance schedules.



CAUTION

- Turn off the power to the burner and controls before proceeding with burner inspection.

Monthly Checklist

1. Inspect flame-sensing devices for good condition and cleanliness.
2. Check for proper air/gas pressures. Refer to the Winnox datasheet, series 111.
3. Test all alarms for proper signals.
4. Check and clean igniter electrodes.
5. Check the air control valve for smooth, trouble free operation and adjustment.
6. Check for the proper operation of ventilating equipment.
7. Test interlock sequence of all safety equipment and manually make each interlock fail, noting that related equipment closes or stops as specified by the manufacturer. Test flame safeguard by manually shutting off gas to burner.
8. Test all manual fuel valves for operation.
9. Clean and/or replace the combustion air blower filter.
10. Inspect and clean the combustion air blower rotor.

Yearly Checklist

1. Test (leak test) safety shut-off valves for tightness of closure.
2. Test pressure switch settings by checking switch movements against pressure settings and compare these with the actual impulse pressure.
3. Visually check ignition cable and connectors.
4. Inspect impulse piping for leaks.
5. Be sure the following components are not damaged or distorted:
 - the burner nozzle
 - the igniter
 - the flame sensors
 - the combustion tube or block

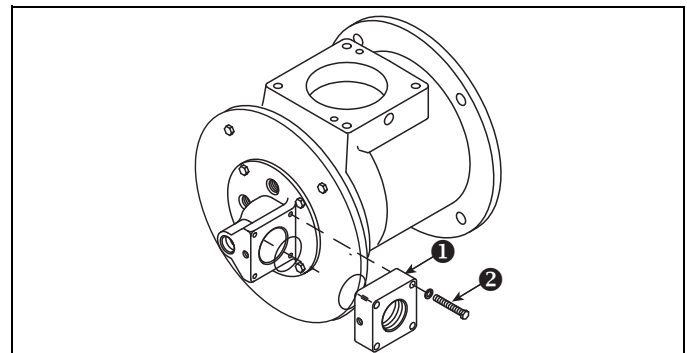

Figure 5.1 Component Inspection

The nozzle can be inspected without removing the burner from the chamber wall or entering the chamber. See Figure 5.1 and Figure 5.2. Perform the following:

- a. Shut the burner off and manually close the main gas shut off cocks.
- b. Allow the chamber temperature to cool down to 250°F (121°C).
- c. Disconnect the gas piping at a union or the gas inlet flange ① provided on the burner.
- d. Remove the four bolts ②.



CAUTION

- Do not attempt to remove the rear cover by removing the inner circle bolts ⑤. Internal burner parts will be damaged.

- Remove bolts ⑥.
- Remove the rear cover / nozzle assembly ③ from the burner housing ④.
- To reassemble, follow this sequence in the reverse order.

NOTE: The combustor can be inspected only by removing the burner from the chamber wall or entering the chamber.

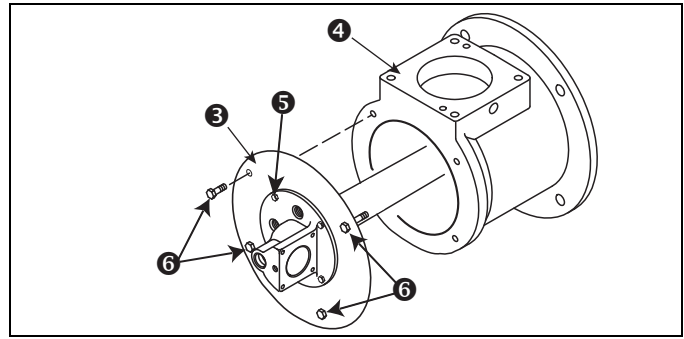

Figure 5.2 Nozzle Inspection

Recommended Spare Parts

To make sure that the downtime of the system is as short as possible in case of a failure, you should keep a stock of spare parts. Please refer to the Eclipse Product Information Center (EPIC) for a full listing of spare parts: <http://www.eclipsenet.com/products>

Troubleshooting

Problem	Possible Cause	Solution
Start-up sequence runs but burner does not light.	No ignition. There is no power to the ignition transformer.	Restore the power to the ignition transformer.
	No ignition. Open circuit between the ignition transformer and the igniter.	Repair or replace the wiring to the igniter.
	No ignition. The igniter needs cleaning.	Clean the igniter.
	No ignition. The igniter is not correctly grounded to the burner.	Clean the threads on the igniter and the burner. NOTE: Do not apply grease to the threads on the igniter.
	No ignition. Igniter insulator is broken. Igniter is grounding out.	Inspect the igniter. Replace if broken.
	Igniter grounds out, igniter is bent.	Inspect ignitor by removing nozzle and rear cover. Check if gaps exist, readjust if needed.
	Not enough gas. The gas pressure into the ratio regulator is too low.	Check the start-up setting. Measure the gas pressures and adjust where necessary.
	Not enough gas. The impulse line to the ratio regulator is leaking.	Repair any leaks.
	Not enough gas. The adjustable orifice valve is not open far enough.	Adjust bypass or low fire gas.
	Not enough gas. Start gas solenoid valve does not open.	Check the solenoid valve coil for proper operation. Replace it if necessary.
	Not enough gas. Gas valve does not open.	Check the wiring to the automatic gas shut-off valve. Check the output from the flame safeguard. Open manual gas cock.
	Not enough gas. Ratio regulator is incorrectly set.	Adjust the ratio regulator to the proper setting.
	No flame signal. Broken flamerod and/or dirty UV scanner lens.	Inspect and clean sensor. Replace if necessary.
Too much gas. Gas butterfly valve too far open.	Check for proper setting.	

Troubleshooting

Problem	Possible Cause	Solution
The low fire flame is weak or unstable.	Not enough gas flowing to the burner.	Adjust the ratio regulator or bypass fuel adjustable orifice valve to increase the gas flow.
	Not enough air.	Check for proper blower rotation. Check air filter for blockage. Compensate for chamber by opening the low fire air butterfly valve position.
The burner goes out when it cycles to high fire.	Not enough gas pressure into the ratio regulator.	Check the start-up settings. Measure the gas pressures and adjust them where necessary. Check for valve train pressure loss.
	Loading line to the ratio regulator is leaking.	Repair the leak in the loading line.
	Not enough gas flowing to the burner.	Adjust the ratio regulator to increase the gas flow.
	Fuel bypass line is not set correctly	Set fuel bypass pressure per datasheet. Additional minor adjustments to the fuel bypass ALO valve may be required to achieve a stable flame through the transition between low and high fire.
The burner is erratic and does not respond to adjustment.	Internal damage to the burner. Some parts inside the burner are loose, dirty or burned out.	Contact Eclipse for further information.
The burner is unstable or produces soot, smoke, or excessive carbon monoxide.	The air/gas ratio is out of adjustment.	Measure all the gas pressures and air pressures. Compare these pressures to the documented initial start-up settings and adjust them where necessary.
The burner cannot achieve full capacity.	Air filter is blocked.	Clean or replace the air filter.
	Gas pressure going into the ratio regulator is too low.	Adjust the gas pressure.
Cannot initiate a start sequence.	Air pressure switch has not made contact.	Check air pressure switch adjustment. Check air filter. Check blower rotation. Check outlet pressure from blower.
	High or low gas pressure switch has activated.	Check incoming gas pressure. Adjust gas pressure if necessary. Check pressure switch setting and operation.
	Malfunction of the flame safeguard system (e.g. shorted-out flame sensor or electrical noise in the sensor line).	Have a qualified electrician troubleshoot and correct the problem.
	No power to the control unit.	Have a qualified electrician troubleshoot and correct the problem.
	Main power is off.	Be sure the main power to the system is switched to the "On" position.

Appendix

Conversion Factors

Metric to English

From	To	Multiply By
actual cubic meter/h (am ³ /h)	actual cubic foot/h (acfh)	35.31
normal cubic meter/h (Nm ³ /h)	standard cubic foot /h (scfh)	38.04
degrees Celsius (°C)	degrees Fahrenheit (°F)	(°C x 9/5) + 32
kilogram (kg)	pound (lb)	2.205
kilowatt (kW)	Btu/h	3415
meter (m)	foot (ft)	3.281
millibar (mbar)	inches water column ("w.c.)	0.402
millibar (mbar)	pounds/sq in (psi)	14.5 x 10 ⁻³
millimeter (mm)	inch (in)	3.94 x 10 ⁻²
MJ/Nm ³	Btu/ft ³ (standard)	26.86







Metric to Metric



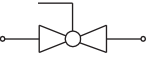
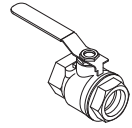
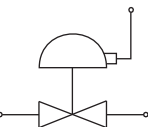
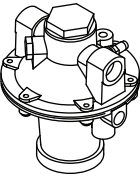

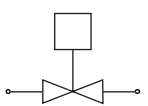
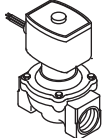



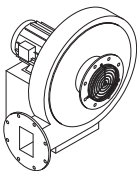

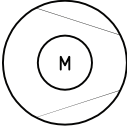
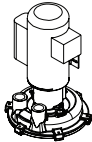
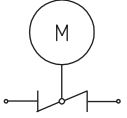
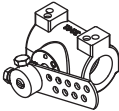
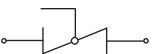
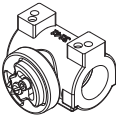
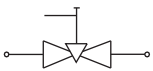

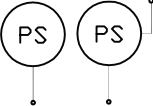
From	To	Multiply By
kiloPascals (kPa)	millibar (mbar)	10
meter (m)	millimeter (mm)	1000
millibar (mbar)	kiloPascals (kPa)	0.1
millimeter (mm)	meter (m)	0.001

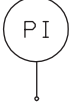
English to Metric

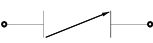
From	To	Multiply By
actual cubic foot/h (acfh)	actual cubic meter/h (am ³ /h)	2.832 x 10 ⁻²
standard cubic foot /h (scfh)	normal cubic meter/h (Nm ³ /h)	2.629 x 10 ⁻²
degrees Fahrenheit (°F)	degrees Celsius (°C)	(°F - 32) x 5/9
pound (lb)	kilogram (kg)	0.454
Btu/h	kilowatt (kW)	0.293 x 10 ⁻³
foot (ft)	meter (m)	0.3048
inches water column ("w.c.)	millibar (mbar)	2.489
pounds/sq in (psi)	millibar (mbar)	68.95
inch (in)	millimeter (mm)	25.4
Btu/ft ³ (standard)	MJ/Nm ³	37.2 x 10 ⁻³

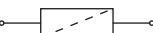
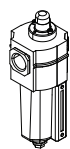
System Schematics

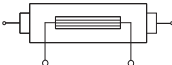
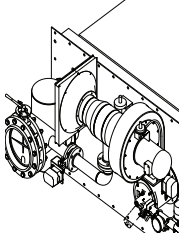
Symbol	Appearance	Name	Remarks	Bulletin/ Info Guide
		Gas Cock	Gas cocks are used to manually shut off the gas supply.	710
		Ratio Regulator	A ratio regulator is used to control the air/gas ratio. The ratio regulator is a sealed unit that adjusts the gas pressure in ratio with the air pressure. To do this, it measures the air pressure with a pressure sensing line, the impulse line. This impulse line is connected between the top of the ratio regulator and the burner body.	
		Main Gas Shut-Off Valve Train	Eclipse strongly endorses NFPA as a minimum.	790/791
		Pilot Gas Valve Train	Eclipse strongly endorses NFPA as a minimum.	790/791
		Automatic Shut-Off Valve	Shut-off valves are used to automatically shut off the gas supply on a gas system or a burner.	760
		Orifice Meter	Orifice meters are used to measure flow.	930
		Combustion Air Blower	The combustion air blower provides the combustion air to the burner(s).	610

Symbol	Appearance	Name	Remarks	Bulletin/ Info Guide
		Hermetic Booster	Booster is used to increase gas pressure.	620
		Automatic Butterfly Valve	Automatic butterfly valves are typically used to set the output of the system.	720
		Manual Butterfly Valve	Manual butterfly valves are used to balance the air or gas flow at each burner.	720
		Adjustable Limiting Orifice	Adjustable limiting orifices are used for fine adjustment of gas flow.	728/730
		Pressure Switch	A switch activated by rise or fall in pressure. A manual reset version requires pushing a button to transfer the contacts when the pressure set point is satisfied.	840
		Pressure Gauge	A device to indicate pressure.	940
		Check Valve	A check valve permits flow only in one direction and is used to prevent back flow of gas.	780
		Strainer	A strainer traps sediment to prevent blockage of sensitive components downstream.	
		Flexible Connector	Flexible connectors isolate components from vibration, mechanical, and thermal stresses.	
		Heat Exchanger	Heat exchangers transfer heat from one medium to another.	500
		Pressure Taps	Pressure taps measure static pressure.	

Notes

Automation and Control Solutions

Honeywell International Inc.
1985 Douglas Drive North
Golden Valley, MN 55422
customer.honeywell.com

® U.S. Registered Trademark
© 2016 Honeywell International Inc.
32-00057-01 M.S. 09-16
Printed in United States

