

Installation instructions for KINEDIZER® burners

Application requirements

View port

A view port to observe burner flame is essential to inspect flame aspect. Locate the view port downstream of the flame, looking back to the burner block. Make sure the complete flame can be evaluated.

Support burner air and gas piping

The KINEDIZER® burner shall not be used as support for the piping to the burner. Gas and air piping shall be supported in such way that no additional loads will be created on the burner.

Burner mounting flange loads

Check burner weight and reinforce burner mounting flange or combustion chamber/furnace back wall if necessary to take complete burner weight.

Installation instructions

Storage of KINEDIZER® burners

KINEDIZER® burners shall be stored dry (inside). Burners blocks have been cured carefully before shipment and shall be kept dry. Wetting of the blocks could result in premature failures.

Handling of KINEDIZER® burners

KINEDIZER® burners are shipped as complete units. Handle burners with care during unpacking, transport, lifting and installation. Use proper equipment. Any impact on the burner could result in damage.

Flange the burner to the installation

Bolt the burner to the installation's burner mounting flange. Use proper gasketing. Tighten the flange bolting with correct torque. Retighten all bolts after first firing and regularly after commissioning.

- 1) Insulation
- 2) Housing
- 3) Gasket (by others)
- 4) Mountings studs
- 5) Burner

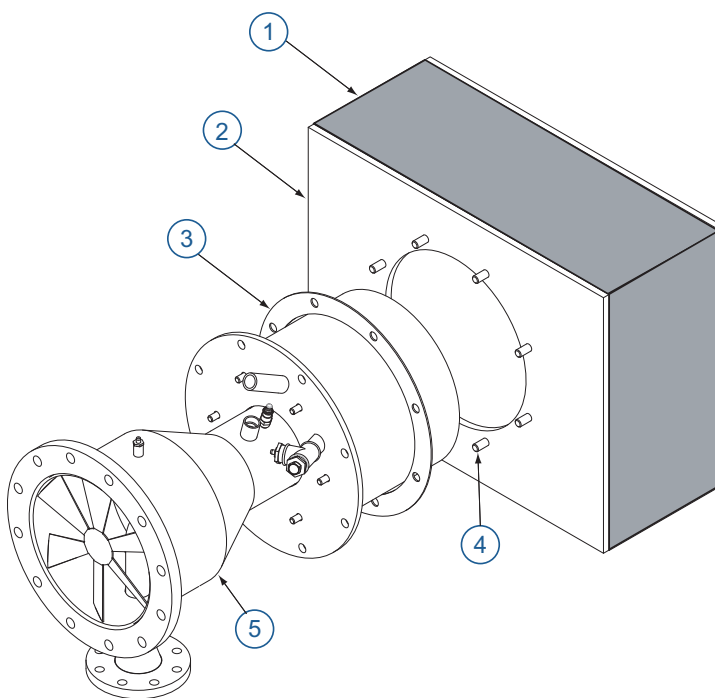

Burner mounting

Furnace/combustion chamber requirements

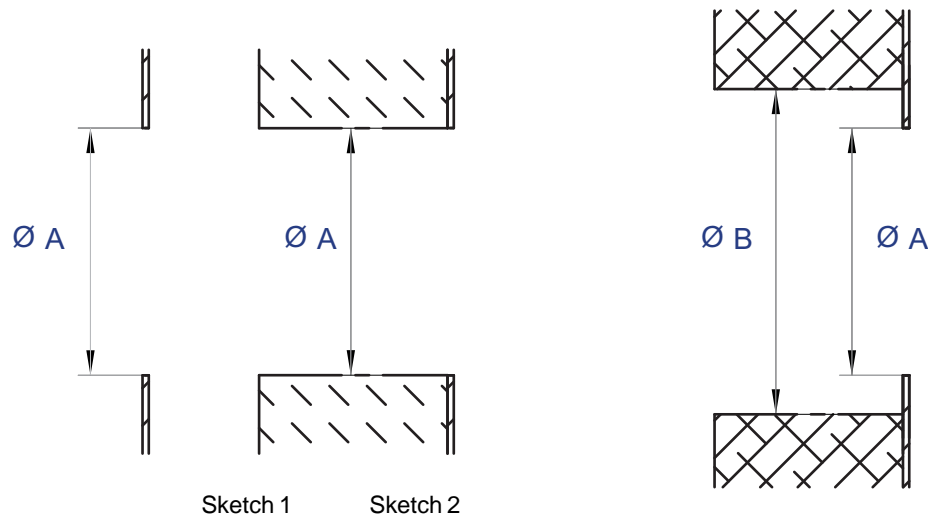

Dimensions in inches unless stated otherwise							
Burner size	.5M	2.5M	5M	9M	18M	27M	40M
ØA (1)	9.6	11.5	14	15.6	17.6	19.7	25
ØB (2)	14.5	16,4	18.9	20.5	22.5	24.6	30

[1] ØA = block diameter + 1 in.

[2] ØB = block diameter + 5.9 in.

Sketch 1 : sheet metal combustion chambers, furnaces without internal insulation or with soft wall internal insulation : flange/ opening internal diameter shall be = ØA.

Sketch 2 : furnaces or ovens with brick walls : opening in brick wall shall be = ØB (to be rammed with castable refractory).

Standard Blocks

Burners with standard blocks require supporting of the burner block by the furnace wall. Ram the gap between block and furnace wall with castable refractory.

- 1) Furnace shell
- 2) Furnace wall
- 3) Castable refractory material

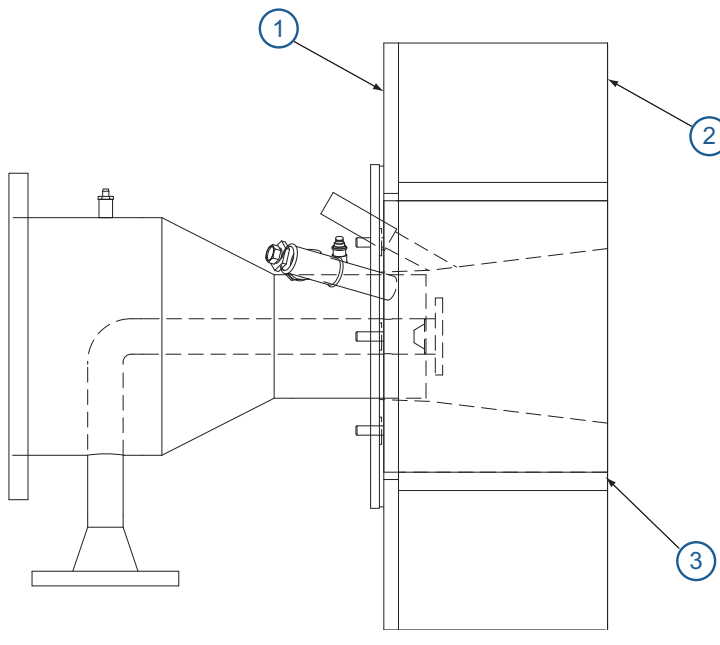

Blocks with supporting sleeve

Burners with blocks that have supporting sleeves can be used in all applications if the supporting sleeve is protected from too high a temperature.

Sheet metal combustion chambers without internal insulation do not require any provision for supporting or protecting the burner blocks.

Furnaces with internal insulation or refractory walls will require protection of the block supporting sleeve from the high temperature. Close the gap between block and furnace wall with soft insulating fibre, to have thermal protection of the block sleeve.

- 1) Furnace shell
- 2) Panel wall
- 3) Soft insulating material

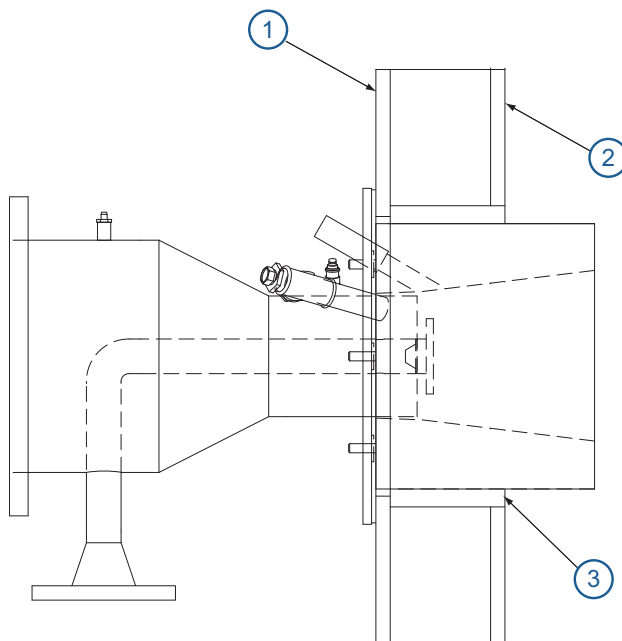

Start-up instructions for KINEDIZER® burners

Instructions provided by the company or individual responsible for the manufacture and/or overall installation of a complete system incorporating MAXON burners take precedence over the installation and operating instructions provided by MAXON. If any of the instructions provided by MAXON are in conflict with local codes or regulations, please contact MAXON before initial start-up of equipment.



Read the combustion system manual carefully before initiating the start-up and adjustment procedure. Verify that all of the equipment associated with and necessary to the safe operation of the burner system has been installed correctly, that all pre-commissioning checks have been carried out successfully and that all safety related aspects of the installation are properly addressed.

Initial adjustment and light-off should be undertaken only by a trained commissioning engineer.

First firing or Restart after shut-down

During first start-up of the burner, and after every longer installation shut-down, the temperature rise shall be limited – allow the burner to fire on low fire for some time to allow the parts to heat-up slowly.

Checks during and after start-up

During and after start-up, check the integrity of the system. Check all bolted connections after first firing (first time on temperature) and retighten if necessary.

Pilot ignition

Before ignition of the pilot, adjust the combustion air to the minimum burner air flow. Pilot will not ignite if too high an air flow. Set pilot gas flow to the correct value before pilot ignition attempt.

Main burner ignition

Set correct gas flow for burner minimum capacity before attempt of main burner ignition.

After ignition of main burner, allow some time on minimum capacity to allow the burner parts to heat up slowly.

Adjust air-gas ratio, set maximum capacity

Once the main flame is ignited, adjust air/gas ratio of the burner to have the required combustion quality and slowly increase capacity (do not increase capacity too fast to avoid damage to burner parts or furnace due to excessive temperature gradient).

Maintenance & inspection instructions

Safety requirements

Regular inspection, testing and recalibration of combustion equipment according to the installation's manual is an integral part of its safety. Inspection activities and frequencies shall be carried out as specified in the installation's manual.

Visual inspections

Regular visual inspection of all connections (air and gas piping to the burner, bolting of the burner to the furnace) and burner flame size and aspect are essential.

Spare parts

Keep local stock of spark ignitor. It is not recommended to keep local stock of other burner parts.

Consult installation manual for burner spare parts and system accessories.